

LMG7380QHFC

256*64 Dots

FEATURES

- ◆ Black on White Film STN Type
- ◆ Transmissive Mode
- ◆ High Brightness CFL Backlight

- ◆ High Contrast LC Material
- ◆ Mechanical Compatibility to LMG63xx series
- ◆ Built-in LCD Controller T6963C

MECHANICAL DATA

Item	Value	Unit
Module Dimensions	160*68*12	mm
Viewing Area	124.3*34	mm
Resolution	256*64	dots
Dot Size	0.44*0.44	mm
Dot Pitch	0.47*0.47	mm
Weight	190	g

OPTICAL DATA

Item	Symbol	Condition	Min	Typ	Max	Unit
Contrast Ratio	K	∅=10°, Q=0°, Note 1	-	20	-	-
Brightness	-	T=25°C, IL=5mA, Note 8	70	90	-	cd/m ²
Viewing Direction	-	-	6			o'clock
Viewing Angle	∅2 - ∅1	K=2, Note 1	30	40	-	degree
Response Time (Rise)	t _R	∅=10°, Q=0°, Note 1	-	(160)	-	ms
Response Time (Fall)	t _F	∅=10°, Q=0°, Note 1	-	(110)	-	ms

ABSOLUTE MAXIMUM RATINGS

Item	Symbol	Condition	Min	Max	Unit
Supply Voltage (Logic)	V _{DD} - V _{SS}	-	0	6.5	V
Supply Voltage (LC Drive)	V _{DD} - V _{EE}	-	0	20.5	V
Input Voltage	V _I	-	-0.3	0.3+V _{DD}	V
Operating Temperature	T _{OP}	Note 5,6	0	50	°C
Storage Temperature	T _{ST}	Note 7	-20	60	°C

DATA INTERFACE PIN ASSIGNMENT

Pin No	Symbol	Level	Function
A1	VSS (0V)	-	Ground
A2	VDD (+5V)	-	Power supply for logic circuit
A3	V0	-	Power supply for LCD drive
A4	C/D	-	WR=Low and C/D=High for Status read, C/D=Low for Data Read
A5	Not WR	-	DW=Low for Data Write
A6	Not RD	-	RD=Low for Data read
A7-A14	DB0 - DB7	-	Display data
A15	Not CE	-	Chip enable (CE must be low)
A16	Not RET	-	Reset
A17	VEE (-15V)	-	Power supply for LCD drive
A18	Not DISP OFF	-	NC for Display ON, GND for Display OFF
A19	F/S	-	Character font selection (F/S=High for 6x8 font, F/S=Low for 8x8 font)
A20	Reverse	-	Display mode reverse

CFL INTERFACE PIN ASSIGNMENT

Pin No	Symbol	Level	Function
1	GND	-	CFL Ground
2	NC	-	No connection
3	NC	-	No connection
4	HV	-	Power supply for CFL

ELECTRICAL CHARACTERISTICS

Item	Symbol	Condition	Min	Typ	Max	Unit
Supply Voltage (Logic)	V _{DD} - V _{SS}	-	4.75	5.0	5.25	V
Supply Voltage (LC Drive)	V _{EE} - V _{SS}	-	-15.5	-15.0	-14.5	V
Supply Current	I _{DD}	Note 2	-	11.0	14.0	mA
	I _{EE}	Note 2	-	1.9	4.0	mA
Input Voltage (High Level)	V _{IH}	High Level	0.8*V _{DD}	-	V _{DD}	V
Input Voltage (Low Level)	V _{IL}	Low Level	0	-	0.2*V _{DD}	V
Frame Frequency	f _{FLM}	Note 4	-	75	-	Hz
Duty Ratio	-	-	-	1/64	-	-
Recommended LC Drive Voltage	V _{DD} - V _O	Duty=1/64, T=0°C, ∅=10°, Note 3	-	16.2	-	V
		Duty=1/64, T=25°C, ∅=10°, Note 3	-	15.0	-	V
		Duty=1/64, T=40°C, ∅=10°, Note 3	-	14.3	-	V
Backlight Lamp Voltage	V _{BL}	T=25°C	-	360	-	Vrms
Backlight Lamp Frequency	f _{BL}	T=25°C	30	70	85	kHz
Backlight Lamp Current	I _{BL}	T=25°C	2.5	5.0	5.5	mA
Lamp Start Voltage	V _S	T=25°C, Note 9	(1000)	-	-	V

TIMING CHARACTERISTICS

Item	Symbol	Min	Typ	Max	Unit
C/D set up time	t _{CDS}	100	-	-	ns
C/D hold time	t _{CHD}	10	-	-	ns
Not CE, Not RD, Not WR pulse width	Not t _{CE} , Not t _{RD} , Not t _{WR}	80	-	-	ns
Data set up time	t _{DS}	80	-	-	ns
Data hold time	t _{DH}	40	-	-	ns
Access time	t _{ACC}	-	-	150	ns
Output hold time	t _{OH}	10	-	50	ns

INVERTER AND CONNECTORS

Recommended Inverter	Starter Kit
HITACHI INVC191	START7380
Data Connector	Data Housing Connector
JAE LZ-20P-SL-SMT-E3000	-
Lamp Connector	Lamp Housing Connector
mitsumi M63M83-04	M61M73-04, M60-04-30-114P or M60-04-30-134P

- Note1: Definition of optical data, see page 84
 Note 2: f_{FRAME}=75Hz, V_{DD}-V₀=15.8V, T_a=25°C
 Note 3: Recommended LCD driving may fluctuate about ± 1.0V by each module.
 Note 4: Need to make sure of flickering and rippling of display when setting the FRAME frequency in your set.
 Note 5: Background colour of the LCD changes depending on temperature. Between 40-50°C optical characteristics of the LCD like contrast and viewing angle change but the display remains readable.
 Note 6: Higher starting voltage of CFL and higher LCD driving voltage are needed while operating at 0°C. The lifetime of CFL will be reduced at 0°C
 Note 7: Storage at -20°C < 48 hr, Storage at 60°C < 168 hr
 Note 8: Measurement after 10 minutes of CFL operating. Brightness control: 100%
 Note 9: Starting discharge voltage is increased when LCM is operating at lower temperature. Please check the characteristics of inverter before applying.



MECHANICAL DIMENSIONS

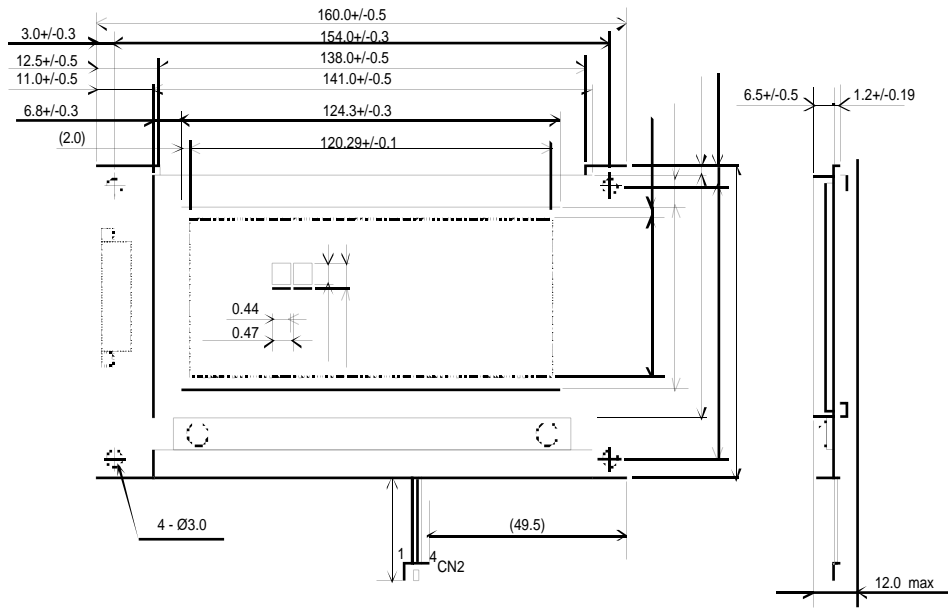

BLOCK DIAGRAM

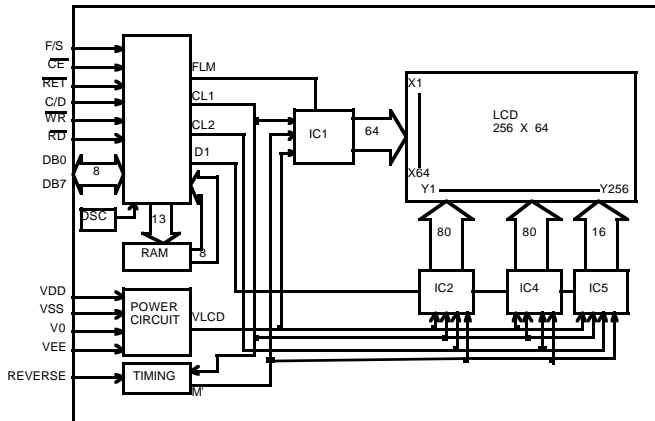

POWER SUPPLY

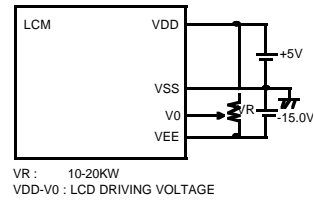

INTERFACE TIMING DIAGRAM

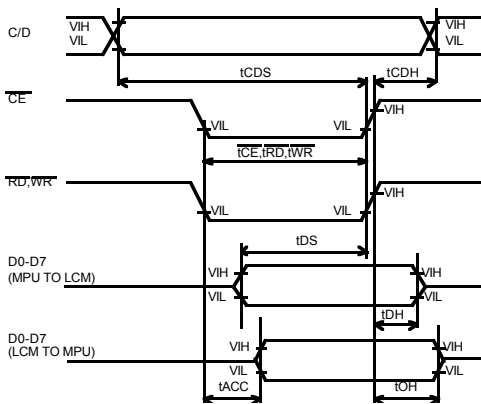

POWER UP TIMING DIAGRAM

