



Chip Type Cermet Trimmer Potentiometer

3mm size, Low profile type

■ Features

- Low profile type (1.2mm in height)
- With rotation stopper
- Achieved excellent endurance characteristics by using "Metal-glaze" film.
- Conform to RoHS Directives
- Reflow solderable



■ Dimensions (Unit: mm)

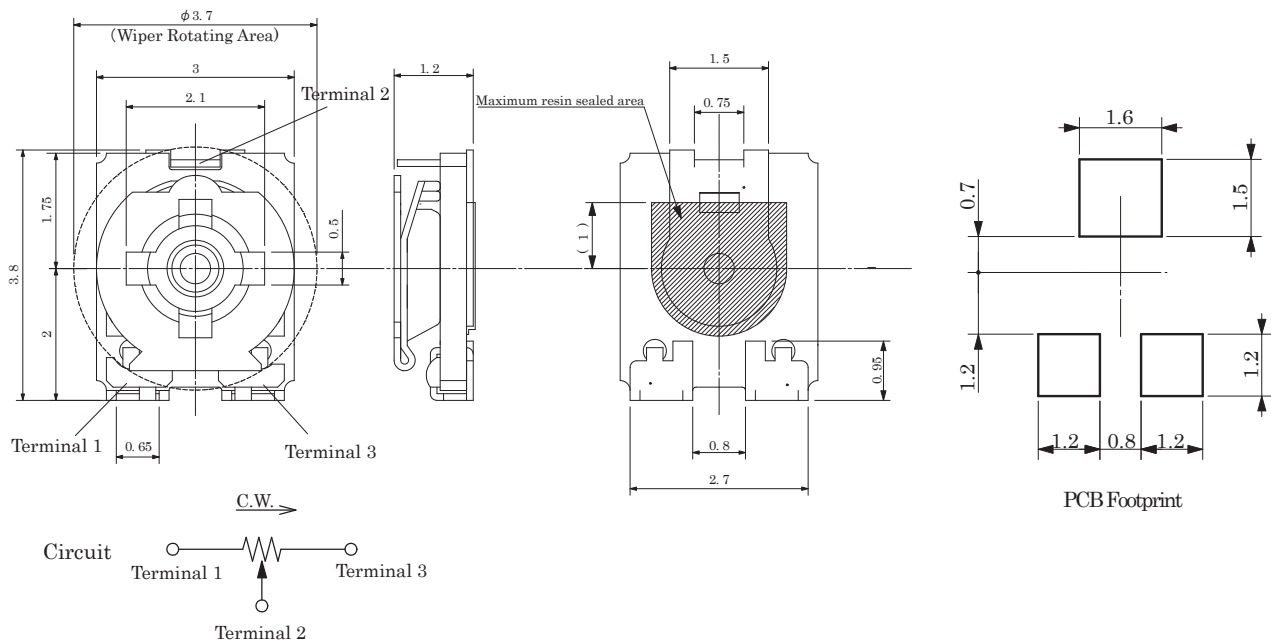

■ Specification

Item	Specification	Unit	Note
Nominal Total Resistance	100 ~ 1 M	Ω	
Resistance Tolerance	± 25	%	
Rotational Torque	0.98 ~ 11.76	mN·m	
End Stop Strength	14.7 min.	mN·m	
Total Mechanical Rotation Angle	270 ± 20	$^{\circ}$	With rotation stopper
Rated Wattage	0.15	W	
Max. Working Voltage	50 or $V = \sqrt{PR}$ whichever is smaller	V	
T.C.R. (Temperature Coefficient of Resistance)	± 250	ppm/ $^{\circ}C$	
Operating Temperature Range	-40 ~ 100	$^{\circ}C$	

■ Model Designation

VG 039N CH XT B***

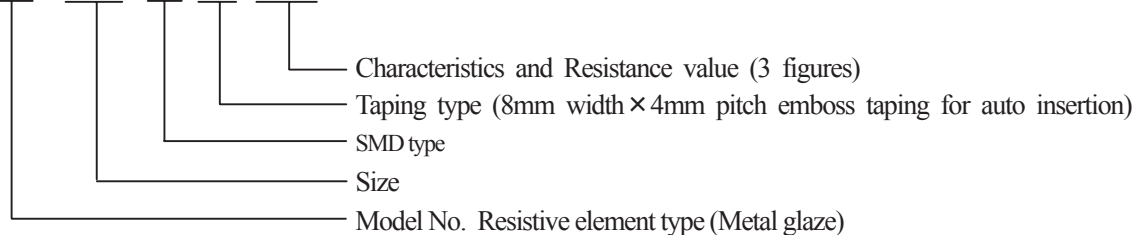

*Packaging Quantity : 2,500pcs / Reel

1. Scope

This specification applies to 3 mm Chip trimmer potentiometer with Metal - Glaze - Resistor, used in electronic equipment.

2. Construction (Dimensions and Materials) and Rating

- 2.1. Dimension See attached Drawing.
- 2.2. Materials See attached Material List
- 2.3. Operating Temperature Range -40 °C~+100 °C
- 2.4. Storage Temperature Range -10 °C~+40 °C
- 2.5. Nominal Total Resistance Range 100 Ω ~ 1 MΩ
(1 · 2 · 3 · 5 series , see attached Application List)
- 2.6. Total Resistance Tolerance ±25 %
- 2.7. Power Rating 0.15 W (~+70 °C)
Power rating vs. ambient temperature shall be denoted on the following chart.

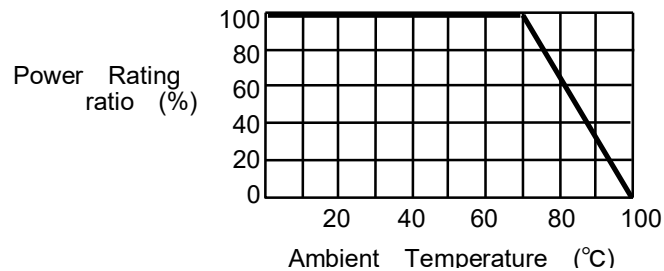

- 2.8. Rated Voltage $E = \sqrt{P \cdot R}$
Where P : Power Rating (W)
R : Nominal Total Resistance (Ω)
When the rated voltage exceeds the maximum operating voltage, the maximum operating voltage shall be the rated voltage.
- 2.9. Maximum Operating Voltage 50 V

③		⑥	
②	Review Item 2.4, 3.3.2	2006.11.11 H.Takabayashi	⑤
①	Add Item 5.4 and review Item 5.	2006.8.2 H.Takabayashi	④
DRAWN N.Kurata DATE Oct./11/'06	CHECKED H.Takabayashi DATE Oct./11/'06	APPROVALS M.Urayama DATE Oct./11/'06	TITLE VARIABLE RESISTOR
DATE Oct. ,11, 2006		HOKURIKU ELECTRIC INDUSTRY CO.,LTD.	HDK TYPE VG039NCH HDK. DWG. NO. W-6522 REV. B 1/7

3. Characteristics

Standard atmospheric conditions

Unless otherwise specified, the standard range of atmospheric conditions for making measurements and tests is as follows :

Ambient temperature : 5 °C to 35 °C
 Relative humidity : 45 % to 85 %
 Air pressure : 860 hPa to 1 060 hPa

If there is any doubt about the results, measurements shall be made within the following limits :

Ambient temperature : 20 °C±2 °C
 Relative humidity : 60 % to 70 %
 Air pressure : 860 hPa to 1 060 hPa

3.1. Mechanical characteristics

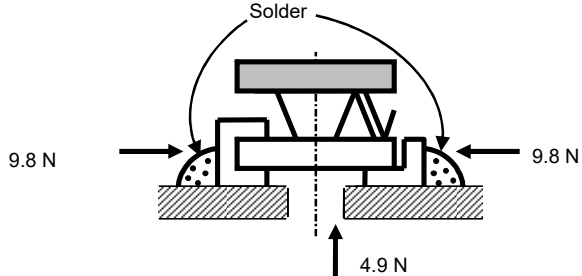
	Item	Conditions	Specifications
1	Total Mechanical Rotation		270 ° ±20 °
2	Rotational Torque		0.98 mN·m ~ 11.76 mN·m
3	End Stop Strength	The following torsion moment of 14.7 mN·m shall be applied to the spindle for 5 seconds in any direction.	Without distinct looseness or poor contact.
4	Soldering Strength	A static load shown in this figure shall be applied to terminals for 30 s after soldering. 	Without distinct looseness or poor contact.
5	Push Load	A push load of 9.8 N shall be applied to the axial direction for 30 seconds from upper part of the product.	Without distinct looseness or poor contact. Without board breaking.

③				⑥		
②				⑤		
①				④		
DRAWN N.Kurata DATE Oct./11/06	CHECKED H.Takabayashi DATE Oct./11/06	APPROVALS M.Urayama DATE Oct./11/06	TITLE VARIABLE RESISTOR	HDK TYPE VG039NCH	REV. B	
DATE Oct. ,11, 2006	HOKURIKU ELECTRIC INDUSTRY CO.,LTD.			HDK. DWG. NO. W-6522	2 / 7	

3. Characteristics

3.2. Electrical characteristics

	Item	Conditions	Specifications										
1	Resistance Law (Taper)	Output voltage ratio at the middle of total rotational angle.	40 % ~ 60 % (Linear taper)										
2	Ineffective Rotation	Ineffective rotation is the sum of all rotational distances in which resistance does not change and is calculated as a percentage of the total mechanical rotation.	10 % or less of total mechanical rotation, at each end.										
3	Residual Resistance	The resistances at each end of the mechanical rotation between terminals 1 and 2, or 2 and 3 shall be measured.	Total nominal resistance 1 kΩ or less										
			Total nominal resistance more than 1 kΩ										
4	Contact Resistance	The moving contact shall be rotated to a point where the resistance between terminals 1 and 2 is half of the total resistance. Contact resistance shall be calculated by the following formula : $\frac{(R_{12}+R_{23})-R_{13}}{2 \times R_{13}} \times 100(\%)$ <p>Where R₁₂ : Resistance between terminals 1 and 2 R₂₃ : Resistance between terminals 2 and 3 R₁₃ : Resistance between terminals 1 and 3</p>	5 % or less of nominal total resistance.										
5	Temperature Coefficient (T. C. R.)	The trimmer potentiometer shall be maintained in a thermostatic chamber at a temperature, according to the table as shown below. <table border="1" style="margin-left: auto; margin-right: auto;"> <thead> <tr> <th>Step</th> <th>Temperature(°C)</th> </tr> </thead> <tbody> <tr> <td>Initial</td> <td>+25±2</td> </tr> <tr> <td>1</td> <td>-40±3</td> </tr> <tr> <td>2</td> <td>+25±2</td> </tr> <tr> <td>3</td> <td>+100±3</td> </tr> </tbody> </table> <p>The measurement shall be made, after the thermostatic chamber achieved the mark temperature and maintained for 30 min ~ 45min.</p>	Step	Temperature(°C)	Initial	+25±2	1	-40±3	2	+25±2	3	+100±3	Within ±250 ppm/°C
Step	Temperature(°C)												
Initial	+25±2												
1	-40±3												
2	+25±2												
3	+100±3												

③				⑥		
②				⑤		
①				④		
DRAWN N.Kurata DATE Oct./11/06	CHECKED H.Takabayashi DATE Oct./11/06	APPROVALS M.Urayama DATE Oct./11/06	TITLE VARIABLE RESISTOR		HDK TYPE VG039NCH	REV. B
DATE Oct. ,11, 2006		HOKURIKU ELECTRIC INDUSTRY CO.,LTD.			HDK. DWG. NO. W-6522	3 / 7

3.3. Endurance characteristics

When the items in ★mark, the moving contact shall be rotated to a point where the resistance between 1 and 2 is half of the total resistance.

	Item	Conditions	Specifications															
1 ★	Vibration	The entire frequency range, from 10 Hz to 55 Hz and return to 10 Hz, shall be transversed in 1 min. Amplitude (total excursion): 1.5 mm This motion shall be applied for a period of 2 h in each of 3 mutually perpendicular directions. (a total of 6 h)	Change in resistance between 1 and 2 is relative to the value before test. Within $\pm 5\%$ Without an instant open during the test.															
2 ★	Resistance to Soldering Heat	<u>Re-flow soldering method</u> Peak temperature : Within 260 °C 10 s Application time : more than 230 °C, Within 40 s <u>Soldering iron method</u> Tip temperature : 400 °C \pm 10 °C Application time of soldering iron : 3 s +1 s / -0 s.	Within $\pm 2\%$ of initial resistance.															
3 ★	High Temperature Storage	The trimmer potentiometer shall be subjected in a thermostatic chamber at a temperature of 70 °C \pm 2 °C without electrical load for 1000 h \pm 12 h. Then the trimmer potentiometer shall be taken out from the chamber and maintained at standard atmospheric conditions for 1 h ~ 2 h, after which measurements shall be made.	Change in total resistance is relative to the value before test. Within $\pm 5\%$															
4 ★	Load Life	The trimmer potentiometer shall be subjected in a thermostatic chamber at a temperature of 70 °C \pm 2 °C with a DC rated voltage for 1.5 h between terminals 1 and 3 followed by a pause of 30 min for 1000 h \pm 12 h. Then the trimmer potentiometer shall be taken out from the chamber and maintained at standard atmospheric conditions for 1 h ~ 2 h without electrical load, after which measurements shall be made.	Change in total resistance is relative to the value before test. Within $\pm 5\%$															
5 ★	Temperature Cycle	The trimmer potentiometer shall be subjected in a thermostatic chamber at 5 successive change of temperature cycles, each as shown in table below. Then the trimmer potentiometer shall be taken out from the chamber and maintained at standard atmospheric conditions for 1 h ~ 2 h, after which measurements shall be made.	Change in total resistance is relative to the value before test. Within $\pm 2\%$ Without distinct looseness or poor contact.															
		<table border="1"> <thead> <tr> <th>Step</th> <th>Temperature</th> <th>Duration</th> </tr> </thead> <tbody> <tr> <td>1</td> <td>-40 °C\pm3 °C</td> <td>30 min</td> </tr> <tr> <td>2</td> <td>Standard atmospheric conditions</td> <td>10 min to 15 min</td> </tr> <tr> <td>3</td> <td>100 °C\pm2 °C</td> <td>30 min</td> </tr> <tr> <td>4</td> <td>Standard atmospheric conditions</td> <td>10 min to 15 min</td> </tr> </tbody> </table>	Step	Temperature	Duration	1	-40 °C \pm 3 °C	30 min	2	Standard atmospheric conditions	10 min to 15 min	3	100 °C \pm 2 °C	30 min	4	Standard atmospheric conditions	10 min to 15 min	
Step	Temperature	Duration																
1	-40 °C \pm 3 °C	30 min																
2	Standard atmospheric conditions	10 min to 15 min																
3	100 °C \pm 2 °C	30 min																
4	Standard atmospheric conditions	10 min to 15 min																

②

③				⑥		
②				⑤		
①				④		
DRAWN N.Kurata DATE Oct./11/06	CHECKED H.Takabayashi DATE Oct./11/06	APPROVALS M.Urayama DATE Oct./11/06	TITLE VARIABLE RESISTOR	HDK TYPE VG039NCH	REV. B	
DATE Oct. ,11, 2006	HOKURIKU ELECTRIC INDUSTRY CO.,LTD.			HDK. DWG. NO. W-6522	4 / 7	

① 5. The others

5.1. Preset Position

The moving contact set half position of total rotation angle (50 %±15 % of total rotation angle) on delivery.

5.2. Application Notes

- The soldering for this product should be reflow soldering. Please note that this product is not applicable to flow soldering.
- Be careful with flying flux in soldering.
- If flux was stuck on the resistance, please wash it out thoroughly by alcoholic solvent.
- Handle the trimmer potentiometer with care.
- This product is not what meant the use to affect the human body life which needs advanced safety and reliability, and the use of nuclear relation, and carried out design manufacture.
- Please refer to EIAJ RCR-2191A "notes guideline(safe application guide of a potentiometer) of the potentiometer for electric devices" about notes on other use.
- In a case where there is a wiring pattern right under this product after mounting. Please be sure to do some insulation measures on the pattern with a resist or some other materials.

5.3. The wish matter of the consideration to the safety of a product

Although we are exerting our best effects to maintain the quality of this product, we cannot guarantee that they will never cause short circuiting and open circuitry.

Therefore, when designing an equipment or device with which the priority is given to the safety, you will please carefully study the influences to the whole equipment of a single function failure of potentiometer in advance to make out a fail-safe design providing.

5.4. Industrial Proprietorship

If the trouble on industrial proprietorship (related on delivered product' s design and production) happens, we solves it on own responsibility.

5.5. Nation of products

CHINA

③					⑥		
②					⑤		
①					④		
DRAWN N.Kurata DATE Oct./11/'06	CHECKED H.Takabayashi DATE Oct./11/'06	APPROVALS M.Urayama DATE Oct./11/'06	TITLE VARIABLE RESISTOR	HDK TYPE VG039NCH	REV. B		
DATE Oct. ,11, 2006	HOKURIKU ELECTRIC INDUSTRY CO.,LTD.			HDK. DWG. NO. W-6522	6 / 7		

6. Taping Specification

- 6.1. Dimension Dwg. No.F-362.022
- 6.2. Taping direction Dwg. No.F-362.022 and Fig.2
- 6.3. Peeling strength of cover tape 0.1 N~0.7 N
- 6.4. Taping method Fig.1
- 6.5. Taping quantity 2 500 pcs./reel

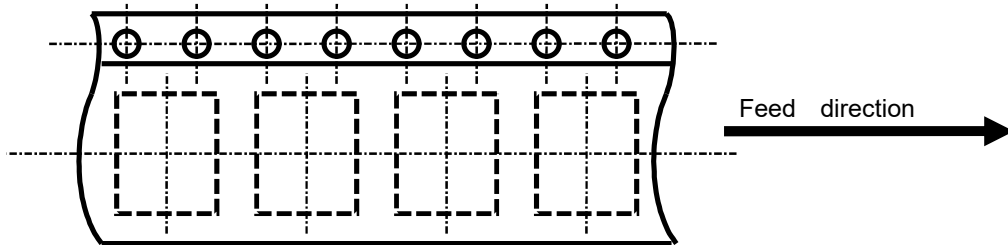
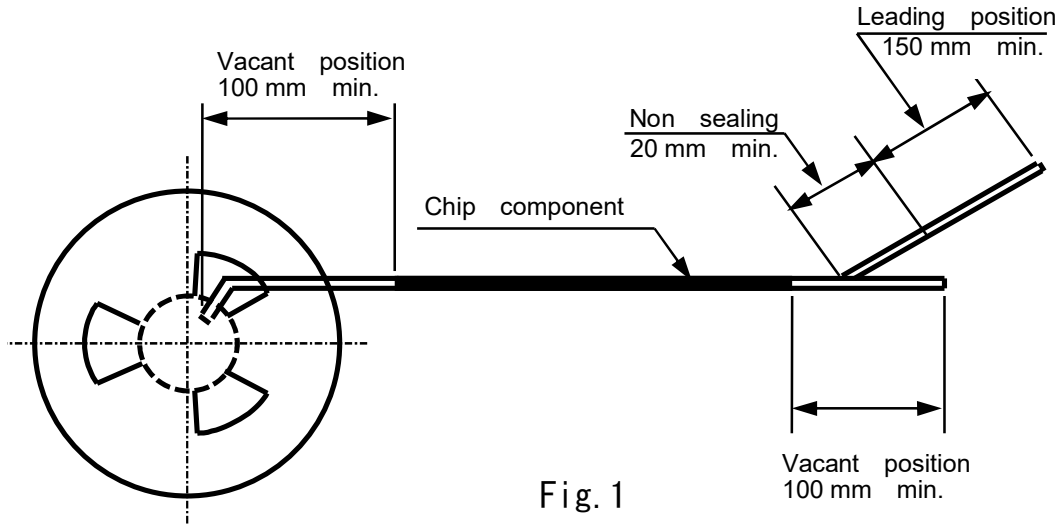

③		⑥			
②		⑤			
①		④			
DRAWN N.Kurata DATE Oct./11/'06	CHECKED H.Takabayashi DATE Oct./11/'06	APPROVALS M.Urayama DATE Oct./11/'06	TITLE VARIABLE RESISTOR	HDK TYPE VG039NCH	REV. B
DATE Oct. ,11, 2006	HOKURIKU ELECTRIC INDUSTRY CO.,LTD.		HDK. DWG. NO. W-6522	7/7	

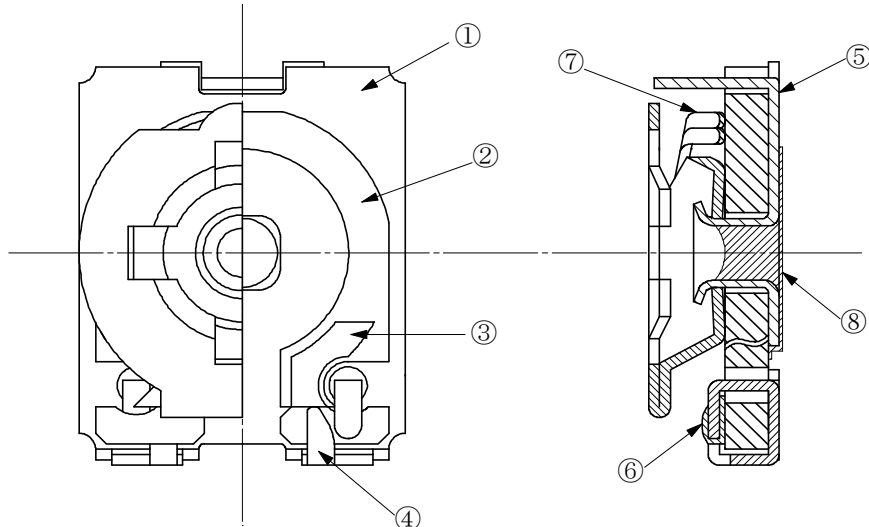

No.	PART NAME 部品名	BASE MATERIAL 材質	PLATING 処理
1	BOARD 基板	CERAMIC Al ₂ O ₃ セラミック (アルミナ)	
2	RESISTOR 抵抗体	METAL GLAZE COATING メタルグレーズ皮膜	
3	ELECTRODE 電極	AgPd 銀パラジウム	
4	1st, 3rd TERMINAL 1番, 3番 端子	STEEL 鋼板	UNDER PLATING Ni : 0.5~2 μm 下地メッキ
			SURFACE PLATING Sn : 2 μm ~ 4 μm 表面メッキ
5	2nd TERMINAL 2番 端子	STEEL 鋼板	UNDER PLATING Ni : 0.5~2 μm 下地メッキ
			SURFACE PLATING Sn : 2 μm ~ 4 μm 表面メッキ
6	TERMINAL JOINT 端子接合部	SOLDER (Sn-3Ag-0.5Cu) 鉛フリー半田	
7	MOVING CONTACT 摺動子	STAINLESS STEEL ステンレス	
① 8	SEALING RESIN 封止樹脂	ACRYL アクリル系	

⑥			
⑤			
④			
③			
②	2007.1.9	下地メッキ厚変更 Correction Under Plating Thickness	高林
①	2006.12.21	No.8 部品名変更 Correction Part Name No.8	高林
	訂正日/Date	訂正理由 / Reason of Correction	訂正者/Corrector

承認/Approved	検図/Checked	設計/Designed	写図/Drawn	文書名 / Title	種別 / HDK TYPE	版/Rev.
浦山 M. Urayama		高林 H. Takabayashi		使用材料表 / Material List	VG039NCH	B
作成日 / Original Date 2006/8/26		北陸電気工業 株式会社 HOKURIKU ELECTRIC INDUSTRY CO., LTD.		仕様書番号 / DWG.NO. W-6502	SHEET 1/1	

適用品一覽表 / Application List

(適用外形寸法図/Drawing : F-362.021,F-362.022)

Rev.	公称全抵抗値 Nominal Total Resistance	抵抗値 許容差 Tolerance	残留抵抗値/Residual Resistance		品番 Part Number	備考 Remark
			1-2 間 Between Terminal #1& #2	2-3 間 Between Terminal #2& #3		
	B100 Ω	±25 %	20 Ω max	20 Ω max		VG039NCHXT B101
	B200 Ω					B201
	B220 Ω					B221
	B300 Ω					B301
	B330 Ω					B331
	B470 Ω					B471
	B500 Ω					B501
	B680 Ω					B681
	B1 kΩ		↓	↓		B102
	B2 kΩ		40 Ω max	40 Ω max		B202
	B2.2 kΩ		44 Ω max	44 Ω max		B222
	B3 kΩ		60 Ω max	60 Ω max		B302
	B3.3 kΩ		66 Ω max	66 Ω max		B332
	B4.7 kΩ		94 Ω max	94 Ω max		B472
	B5 kΩ		100 Ω max	100 Ω max		B502
	B6.8 kΩ		136 Ω max	136 Ω max		B682
	B10 kΩ		200 Ω max	200 Ω max		B103
	B20 kΩ		400 Ω max	400 Ω max		B203
	B22 kΩ		440 Ω max	440 Ω max		B223
	B30 kΩ		600 Ω max	600 Ω max		B303
	B33 kΩ		660 Ω max	660 Ω max		B333
	B47 kΩ		940 Ω max	940 Ω max		B473
	B50 kΩ		1 kΩ max	1 kΩ max		B503
	B68 kΩ		1.36 kΩ max	1.36 kΩ max		B683
	B100 kΩ		2 kΩ max	2 kΩ max		B104
	B200 kΩ		4 kΩ max	4 kΩ max		B204
	B220 kΩ		4.4 kΩ max	4.4 kΩ max		B224
	B300 kΩ		6 kΩ max	6 kΩ max		B304
	B330 kΩ		6.6 kΩ max	6.6 kΩ max		B334
	B470 kΩ		9.4 kΩ max	9.4 kΩ max		B474
	B500 kΩ		10 kΩ max	10 kΩ max		B504
	B680 kΩ		13.6 kΩ max	13.6 kΩ max		B684
	B1 MΩ	↓	20 kΩ max	20 kΩ max		B105

⑥			
⑤			
④			
③			
②			
①			

訂正日/Date		訂正理由 / Reason of Correction			記事 / Account	
承認/Approved 浦山 M. Urayama	検図/Checked	設計/Designed 高林 H. Takabayashi	写図/Drawn	文書名 / Title 製品規格 / Variable resistor	種別 / HDK TYPE VG039NCHXT	版/Rev.
作成日 / Original Date 2006/8/28		北陸電気工業 株式会社 HOKURIKU ELECTRIC INDUSTRY CO., LTD.			仕様書番号 / DWG.NO. W-6500	SHEET 1/1

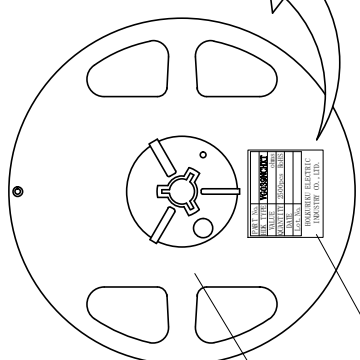

Label description

- PART No. : Per customer's directions
- VALUE : Indication of the resistance value (Ex. 100)
- QUANTITY : Label for the reel
- LEADLESS SOLDER : "RoHS"
- Date : Indication of taping date (Ex. 02.4.18)
- Lot.No. : Indication of HDK manufacturing lot No. (Ex. Q-16-5-1)

PART No.	①
HDK TYPE	VG039NCHXT
VALUE	② ohms
QUANTITY	③ 2500pcs ④RoHS
DATE	⑤
Lot.No.	⑥
HOKURIKU ELECTRIC INDUSTRY CO., LTD.	

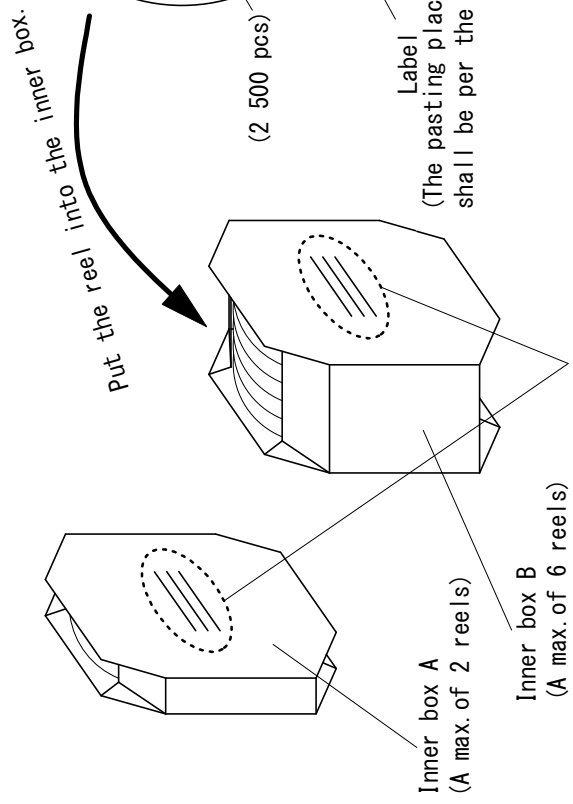

Inner box A
(A max. of 2 reels)

Inner box B
(A max. of 6 reels)

Type name, Resistance value and quantity are filled in. Note 4.

Packaging Specification

	Number of the reels put in	Total Quantity of the products
Inner box A	A max of 2 reels	5 000 pcs. max.
Inner box B	A max of 6 reels	15 000 pcs. max.

	Number of the reels put in	Total Quantity of the products	Size (W*L*H) (Unit : mm)
Outer box a	A max of 6 reels	15 000 pcs. max.	290*210*90
Outer box b	A max of 12 reels	30 000 pcs. max.	505*210*90
Outer box c	A max of 24 reels	60 000 pcs. max.	400*220*180
Outer box d	A max of 48 reels	120 000 pcs. max.	400*220*330
Outer box e	A max of 30 reels	75 000 pcs. max.	390*210*225

- Note 1- Glue the label on the reel (The gluing position is per the drawing.)
- Note 2- Cushion material is to be put in to fill the empty space when the number of the reels in an inner box does not reach 2 or 6 respectively.
- Note 3- Cushion material is to be put in to fill the empty space when the total quantity in the outer box does not reach 15 000 , 30 000 , 60 000 , 75 000 , or 120 000 pcs. respectively.
- Note 4- Type name, resistance value and quantity shall be written on a inner box.

Example : VG039NCHXT
B 1 k ohm
15 000

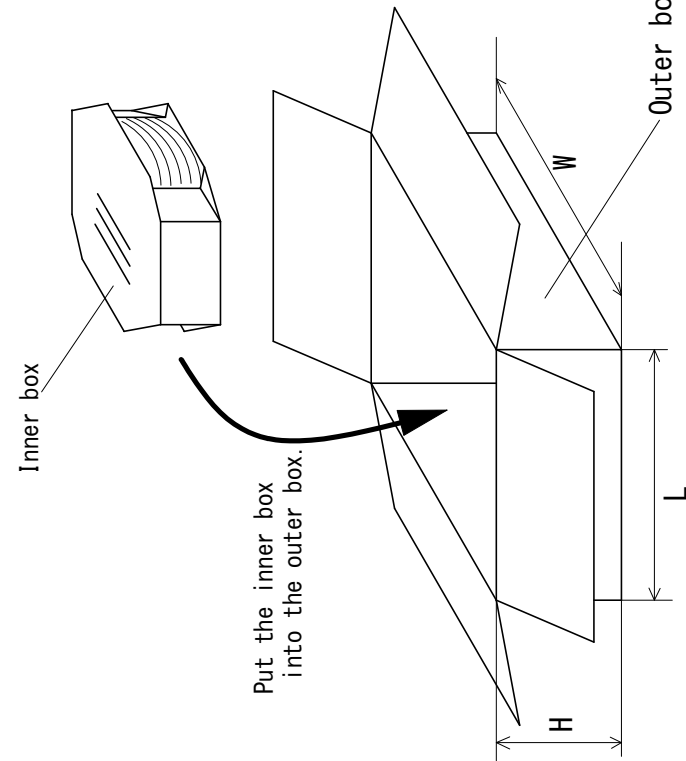

Put the inner box into the outer box.

REVISIONS			
DRAWN	CHECKED	APPROVED	TITLE
N. Kurata		H. Takabayashi	VARIABLE RESISTOR
DATE: Oct. 11, 2006	DATE	DATE: Oct. 11, 2006	SCALE 5/1
TOLERANCE UNLESS OTHERWISE SPECIFIED			HDK DWG No. R-2832
			REV. REV.