

## Thermally-Enhanced High Power RF LDMOS FETs 240 W, 1805 – 1880 MHz

### Description

The PTFB182503EL and PTFB182503FL are 240-watt LDMOS FETs intended for use in multi-standard cellular power amplifier applications in the 1805 to 1880 MHz frequency band. Features include input and output matching, high gain, wide signal bandwidth and reduced memory effects for improved DPD correctability. Manufactured with Infineon's advanced LDMOS process, these devices provide excellent thermal performance and superior reliability.

PTFB182503EL  
H-33288-6



PTFB182503FL  
H-34288-4/2

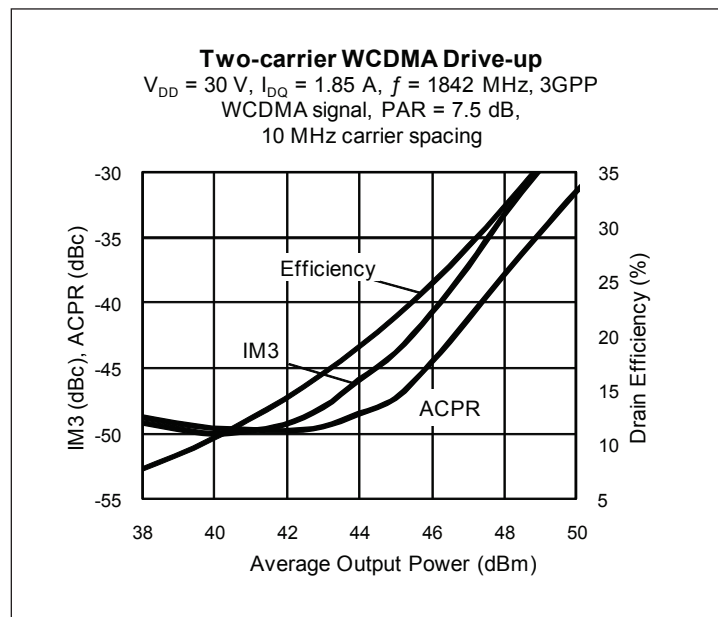

### Features

- Broadband internal input and output matching
- Enhanced for use in DPD error correction systems
- Typical two-carrier WCDMA performance, 1880 MHz, 30 V
  - Average output power = 50 W
  - Linear gain = 19 dB
  - Drain efficiency = 28 %
  - Intermodulation distortion = -35 dBc
- Typical CW performance, 1880 MHz, 30 V
  - Output power at  $P_{1dB}$  = 240 W
  - Efficiency = 55%
- Increased negative gate-source voltage range for improved performance in Doherty peaking amplifiers
- Integrated ESD protection. Human Body Model, Class 2 (minimum)
- Capable of handling 10:1 VSWR @ 30 V, 240 W (CW) output power
- Pb-free, RoHS compliant

### RF Characteristics

#### Two-carrier WCDMA Specifications (tested in Infineon test fixture)

$V_{DD} = 30\text{ V}$ ,  $I_{DQ} = 1.85\text{ A}$ ,  $P_{OUT} = 50\text{ W}$  average

$f_1 = 1840\text{ MHz}$ ,  $f_2 = 1845\text{ MHz}$ , 3GPP signal, channel bandwidth = 3.84 MHz, peak/average = 7.5 dB @ 0.01% CCDF

Characteristic	Symbol	Min	Typ	Max	Unit
Gain	$G_{ps}$	18	19	—	dB
Drain Efficiency	$\eta_D$	27	28	—	%
Intermodulation Distortion	IMD	—	-35	-31	dBc

All published data at  $T_{CASE} = 25^\circ\text{C}$  unless otherwise indicated

**ESD:** Electrostatic discharge sensitive device—observe handling precautions!

## RF Characteristics (cont.)

**Two-tone Specifications** (not subject to production test—verified by design/characterization in Infineon test fixture)  
 $V_{DD} = 30\text{ V}$ ,  $I_{DQ} = 1.85\text{ A}$ ,  $P_{OUT} = 220\text{ W PEP}$ ,  $f = 1840\text{ MHz}$ , tone spacing = 1 MHz

Characteristic	Symbol	Min	Typ	Max	Unit
Gain	$G_{ps}$	—	18	—	dB
Drain Efficiency	$\eta_D$	—	40	—	%
Intermodulation Distortion	IMD	—	-28	—	dBc

## DC Characteristics

Characteristic	Conditions	Symbol	Min	Typ	Max	Unit
Drain-Source Breakdown Voltage	$V_{GS} = 0\text{ V}$ , $I_{DS} = 10\text{ mA}$	$V_{(BR)DSS}$	65	—	—	V
Drain Leakage Current	$V_{DS} = 28\text{ V}$ , $V_{GS} = 0\text{ V}$	$I_{DSS}$	—	—	1.0	$\mu\text{A}$
Drain Leakage Current	$V_{DS} = 63\text{ V}$ , $V_{GS} = 0\text{ V}$	$I_{DSS}$	—	—	10.0	$\mu\text{A}$
On-State Resistance	$V_{GS} = 10\text{ V}$ , $V_{DS} = 0.1\text{ V}$	$R_{DS(on)}$	—	0.03	—	$\Omega$
Operating Gate Voltage	$V_{DS} = 30\text{ V}$ , $I_{DQ} = 1.85\text{ A}$	$V_{GS}$	2.3	2.8	3.3	V
Gate Leakage Current	$V_{GS} = 10\text{ V}$ , $V_{DS} = 0\text{ V}$	$I_{GSS}$	—	—	1.0	$\mu\text{A}$

## Maximum Ratings

Parameter	Symbol	Value	Unit
Drain-Source Voltage	$V_{DSS}$	65	V
Gate-Source Voltage	$V_{GS}$	-6 to +10	V
Operating Voltage	$V_{DD}$	24 to 30	V
Junction Temperature	$T_J$	200	$^{\circ}\text{C}$
Storage Temperature Range	$T_{STG}$	-40 to +150	$^{\circ}\text{C}$
Thermal Resistance ( $T_{CASE} = 70^{\circ}\text{C}$ , 50 W WCDMA)	$R_{\theta JC}$	0.262	$^{\circ}\text{C/W}$

## Ordering Information

Type and Version	Order Code	Package Description	Shipping
PTFB182503EL V1	PTFB182503ELV1XWSA1	H-33288-6, slotted flange	Tray
PTFB182503EL V1 R250	PTFB182503ELV1R250XTMA1	H-33288-6, slotted flange	Tape & Reel, 250 pcs
PTFB182503FL V2	PTFB182503FLV2XWSA1	H-34288-4/2, earless flange	Tray
PTFB182503FL V2 R250	PTFB182503FLV2R250XTMA1	H-34288-4/2, earless flange	Tape & Reel, 250 pcs

**Typical Performance** (data taken in a production test fixture)

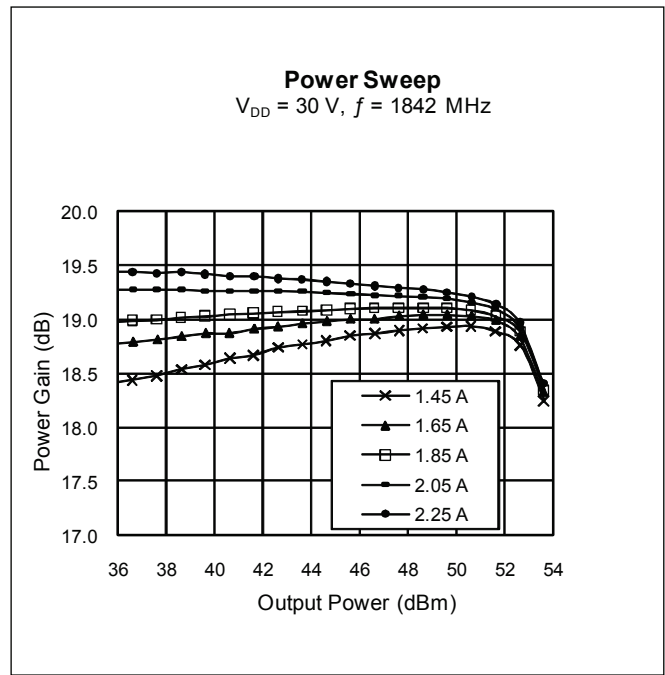
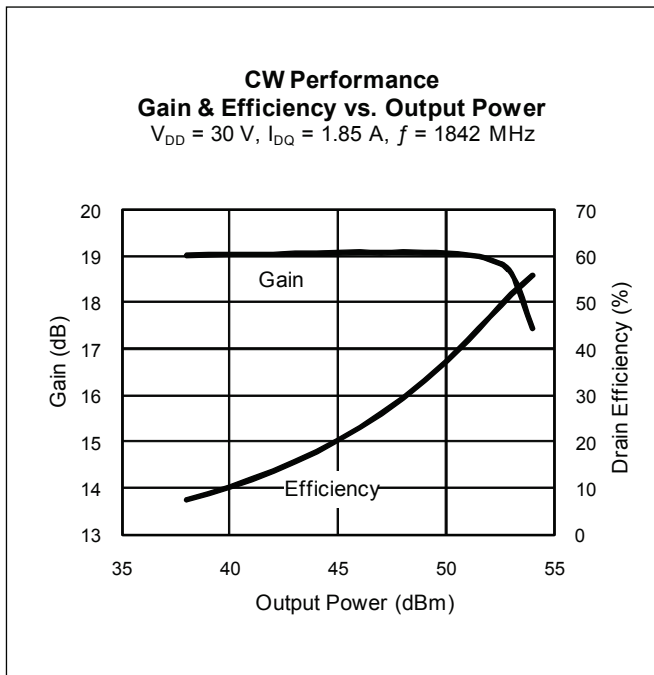
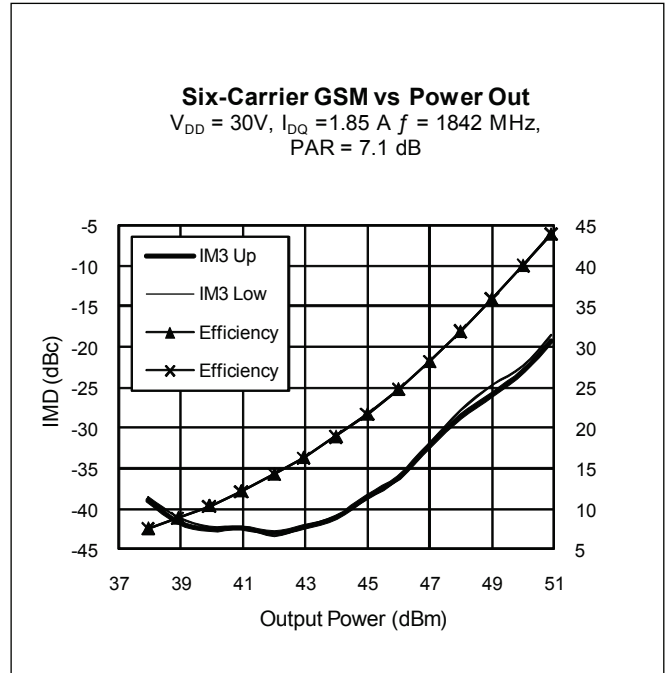
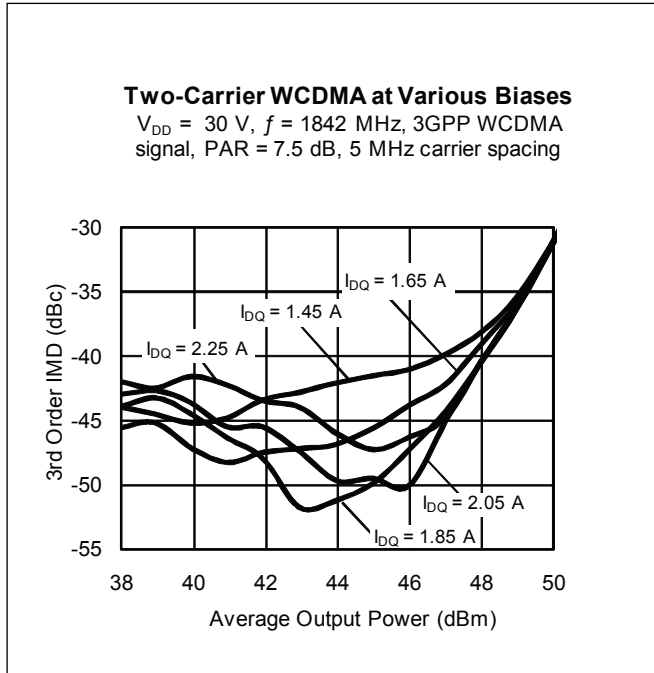

Typical Performance (cont.)

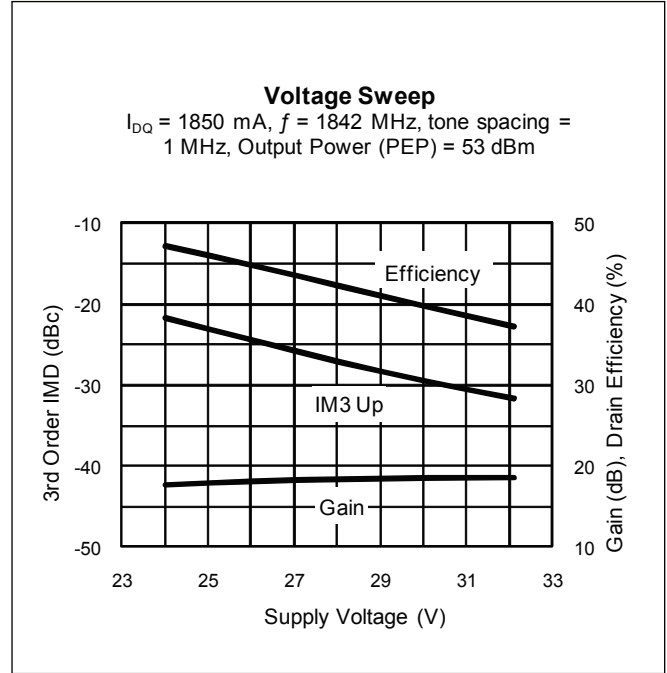
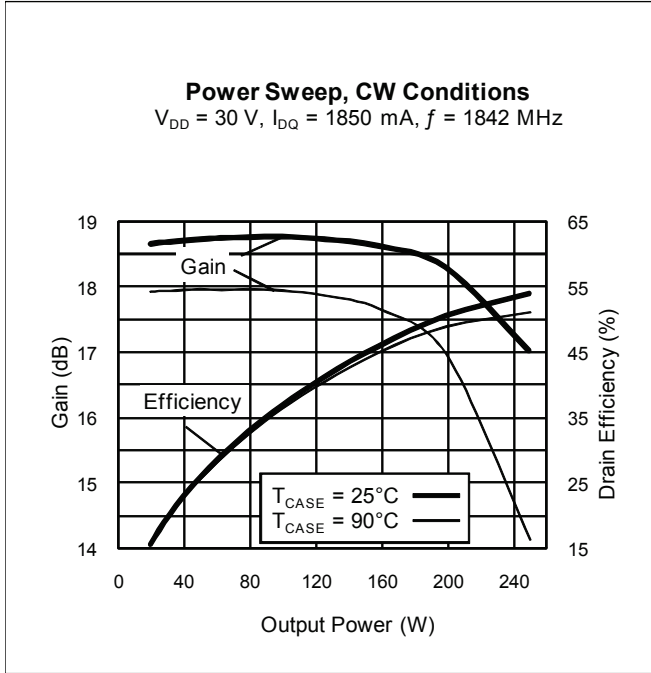

Broadband Circuit Impedance

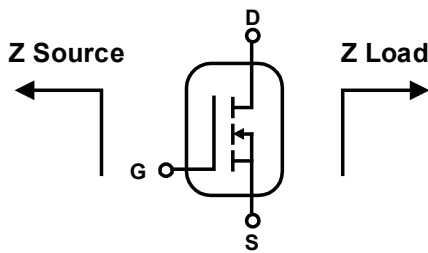

Frequency MHz	Z Source $\Omega$		Z Load $\Omega$	
	R	jX	R	jX
1780	2.99	-2.48	1.33	-0.49
1800	2.95	-2.30	1.33	-0.38
1820	2.89	-2.13	1.31	-0.27
1840	2.84	-1.96	1.29	-0.16
1860	2.80	-1.76	1.29	-0.02
1880	2.78	-1.58	1.28	0.10
1900	2.74	-1.39	1.29	0.23
1920	2.72	-1.21	1.29	0.36

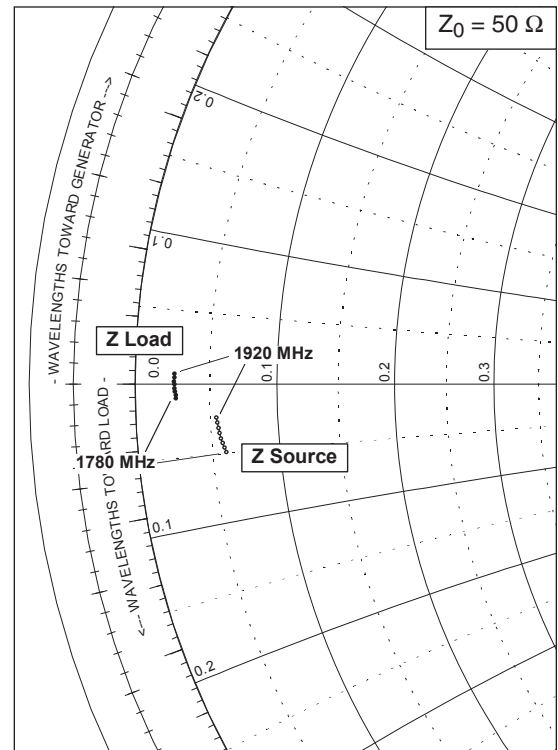

### Reference Circuit

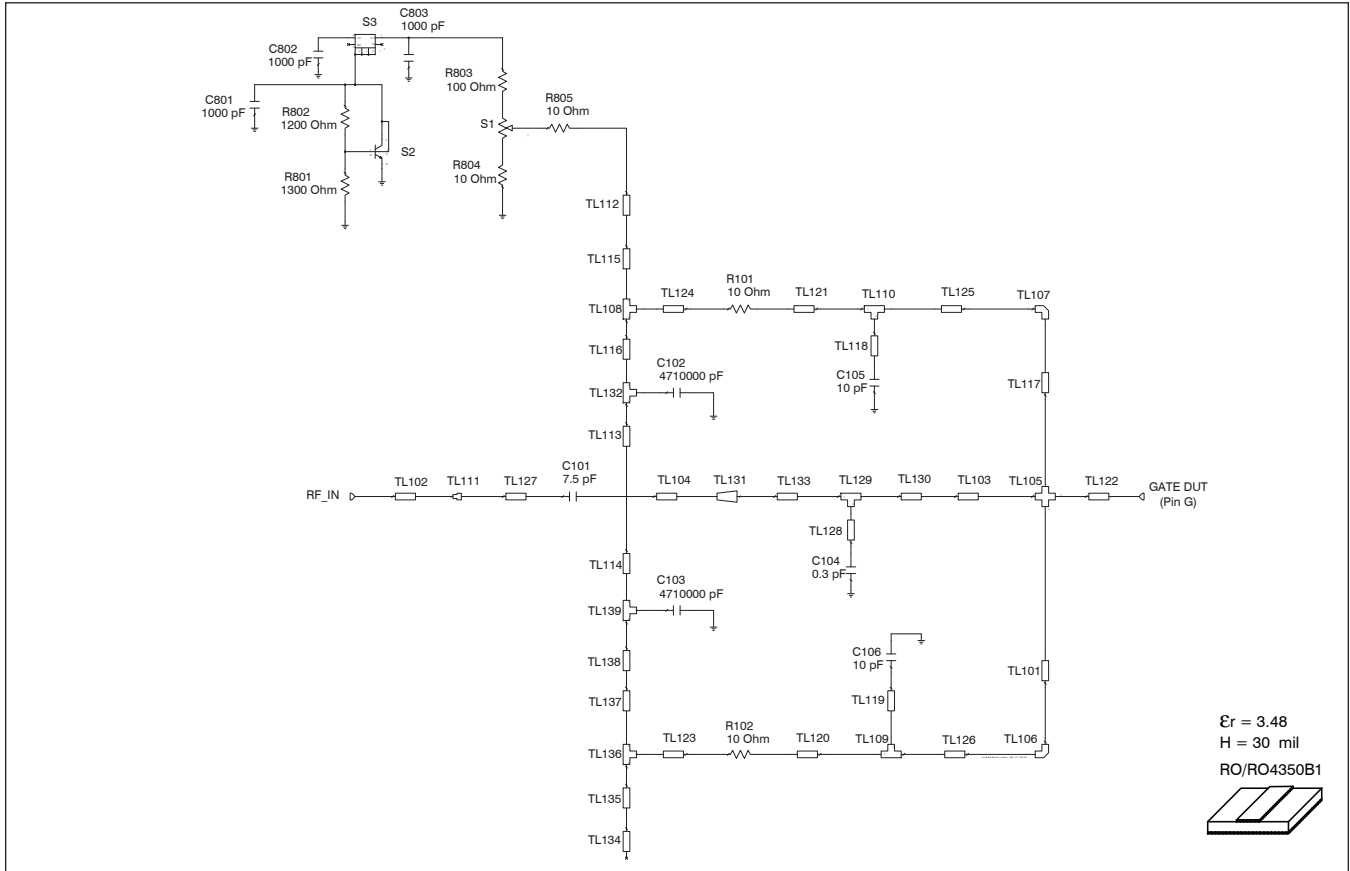

Reference circuit input schematic for  $f = 1880 \text{ MHz}$

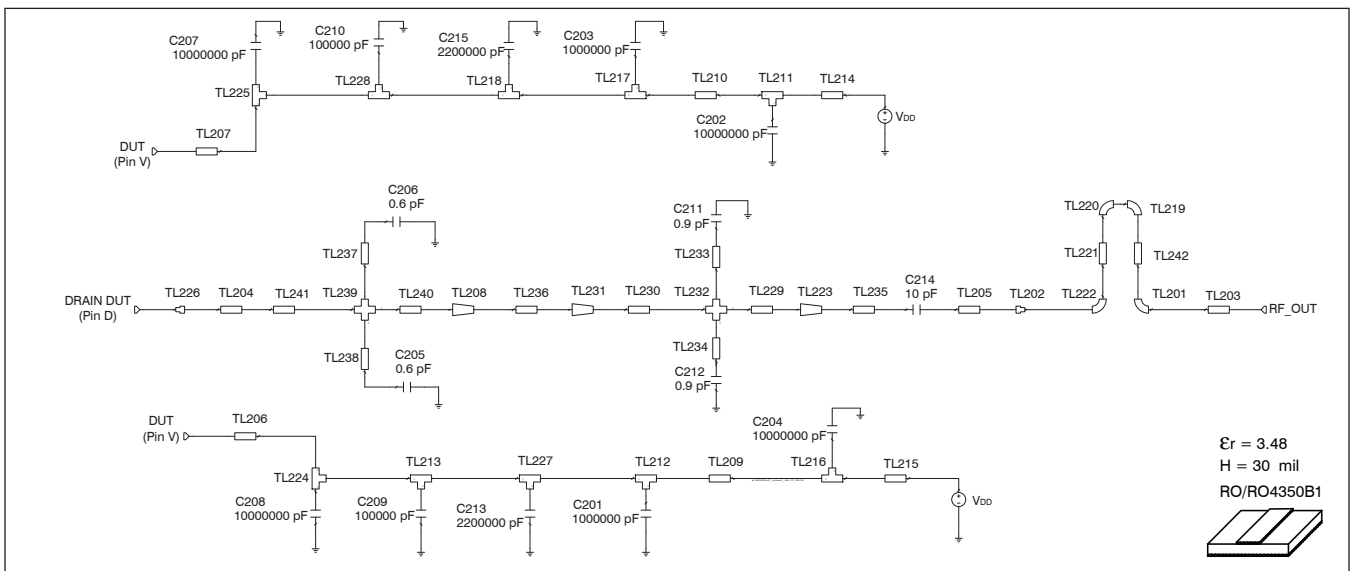

Reference circuit output schematic for  $f = 1880 \text{ MHz}$

## Reference Circuit (cont.)

### Description

DUT	PTFB182503EL or PTFB182503FL
PCB	0.76 mm [.030"] thick, $\epsilon_r = 3.48$ , Rogers 4350, 1 oz. copper

### Electrical Characteristics at 1880 MHz

Transmission Line	Electrical Characteristics	Dimensions: mm	Dimensions: mils
<b>Input</b>			
TL101, TL117	$0.022 \lambda$ , 78.27 $\Omega$	W = 0.762, L = 2.159	W = 30, L = 85
TL102	$0.035 \lambda$ , 51.58 $\Omega$	W = 1.651, L = 3.358	W = 65, L = 132
TL103	$0.050 \lambda$ , 9.67 $\Omega$	W = 13.970, L = 4.445	W = 550, L = 175
TL104	$0.031 \lambda$ , 51.58 $\Omega$	W = 1.651, L = 3.018	W = 65, L = 119
TL105		W1 = 13.970, W2 = 0.762, W3 = 13.970, W4 = 0.762	W1 = 550, W2 = 30, W3 = 550, W4 = 30
TL106, TL107		W = 0.762	W = 30
TL108, TL136	$0.010 \lambda$ , 68.02 $\Omega$	W1 = 1.016, W2 = 1.016, W3 = 1.016	W1 = 40, W2 = 40, W3 = 40
TL109, TL110, TL132, TL139	$0.010 \lambda$ , 78.27 $\Omega$	W1 = 0.762, W2 = 0.762, W3 = 1.016	W1 = 30, W2 = 30, W3 = 40
TL111		W1 = 1.651, W2 = 2.032	W1 = 65, W2 = 80
TL112, TL134	$0.014 \lambda$ , 38.82 $\Omega$	W = 2.540, L = 1.321	W = 100, L = 52
TL113	$0.020 \lambda$ , 78.27 $\Omega$	W = 0.762, L = 2.007	W = 30, L = 79
TL114	$0.099 \lambda$ , 92.53 $\Omega$	W = 0.508, L = 9.957	W = 20, L = 392
TL115	$0.016 \lambda$ , 68.02 $\Omega$	W = 1.016, L = 1.524	W = 40, L = 60
TL116, TL137	$0.017 \lambda$ , 78.27 $\Omega$	W = 0.762, L = 1.727	W = 30, L = 68
TL118, TL119	$0.001 \lambda$ , 68.02 $\Omega$	W = 1.016, L = 0.127	W = 40, L = 5
TL120, TL121	$0.013 \lambda$ , 78.27 $\Omega$	W = 0.762, L = 1.270	W = 30, L = 50
TL122	$0.022 \lambda$ , 9.67 $\Omega$	W = 13.970, L = 1.981	W = 550, L = 78
TL123, TL124	$0.007 \lambda$ , 68.02 $\Omega$	W = 1.016, L = 0.686	W = 40, L = 27
TL125, TL126	$0.118 \lambda$ , 78.27 $\Omega$	W = 0.762, L = 11.684	W = 30, L = 460
TL127	$0.008 \lambda$ , 45.17 $\Omega$	W = 2.032, L = 0.762	W = 80, L = 30
TL128	$0.000 \lambda$ , 45.17 $\Omega$	W = 2.032, L = 0.025	W = 80, L = 1
TL129	$0.023 \lambda$ , 9.67 $\Omega$	W1 = 13.970, W2 = 13.970, W3 = 2.032	W1 = 550, W2 = 550, W3 = 80
TL130	$0.000 \lambda$ , 9.67 $\Omega$	W = 13.970, L = 0.025	W = 550, L = 1
TL131 (taper)	$0.028 \lambda$ , 9.67 $\Omega$ / 51.58 $\Omega$	W1 = 13.970, W2 = 1.651, L = 2.515	W1 = 550, W2 = 65, L = 99
TL133	$0.050 \lambda$ , 9.67 $\Omega$	W = 13.970, L = 4.470	W = 550, L = 176
TL135	$0.015 \lambda$ , 68.02 $\Omega$	W = 1.016, L = 1.514	W = 40, L = 60
TL138	$0.010 \lambda$ , 78.27 $\Omega$	W = 0.762, L = 0.991	W = 30, L = 39

table continued on page 7

## Reference Circuit (cont.)

### Electrical Characteristics at 1880 MHz

Transmission Line	Electrical Characteristics	Dimensions: mm	Dimensions: mils
<b>Output</b>			
TL201, TL219, TL220, TL222		W = 0.002, ANG = 90.000, R = 0.002	W = 2, ANG = 3543307, R = 70
TL202		W1 = 1.651, W2 = 2.032	W1 = 65, W2 = 80
TL203	0.012 $\lambda$ , 51.58 $\Omega$	W = 1.651, L = 1.118	W = 65, L = 44
TL204	0.084 $\lambda$ , 6.86 $\Omega$	W = 20.320, L = 7.366	W = 800, L = 290
TL205	0.011 $\lambda$ , 45.17 $\Omega$	W = 2.032, L = 1.016	W = 80, L = 40
TL206	0.028 $\lambda$ , 23.60 $\Omega$	W = 4.928, L = 2.540	W = 194, L = 100
TL207	0.028 $\lambda$ , 23.79 $\Omega$	W = 4.877, L = 2.540	W = 192, L = 100
TL208 (taper)	0.018 $\lambda$ , 6.86 $\Omega$ / 8.31 $\Omega$	W1 = 20.320, W2 = 16.510, L = 1.575	W1 = 800, W2 = 650, L = 62
TL209, TL210	0.076 $\lambda$ , 34.08 $\Omega$	W = 3.048, L = 7.112	W = 120, L = 280
TL211, TL216, TL224, TL225	0.032 $\lambda$ , 34.08 $\Omega$	W1 = 3.048, W2 = 3.048, W3 = 3.048	W1 = 120, W2 = 120, W3 = 120
TL212, TL228, TL217, TL218, TL227	0.024 $\lambda$ , 34.08 $\Omega$	W1 = 3.048, W2 = 3.048, W3 = 2.286	W1 = 120, W2 = 120, W3 = 90
TL213	0.008 $\lambda$ , 34.08 $\Omega$	W1 = 3.048, W2 = 3.048, W3 = 0.762	W1 = 120, W2 = 120, W3 = 30
TL214, TL215	0.051 $\lambda$ , 34.08 $\Omega$	W = 3.048, L = 4.826	W = 120, L = 190
TL221, TL242	0.013 $\lambda$ , 51.58 $\Omega$	W = 1.651, L = 1.270	W = 65, L = 50
TL223 (taper)	0.018 $\lambda$ , 19.45 $\Omega$ / 51.58 $\Omega$	W1 = 6.248, W2 = 1.651, L = 1.651	W1 = 246, W2 = 65, L = 65
TL226		W1 = 12.700, W2 = 17.780	W1 = 500, W2 = 700
TL229, TL230	0.000 $\lambda$ , 19.45 $\Omega$	W = 6.248, L = 0.025	W = 246, L = 1
TL231 (taper)	0.038 $\lambda$ , 8.31 $\Omega$ / 19.45 $\Omega$	W1 = 16.510, W2 = 6.248, L = 3.378	W1 = 650, W2 = 246, L = 133
TL232		W1 = 6.248, W2 = 0.025, W3 = 6.248, W4 = 0.025	W1 = 246, W2 = 1, W3 = 246, W4 = 1
TL233, TL234, TL237, TL238	0.000 $\lambda$ , 146.88 $\Omega$	W = 0.025, L = 0.025	W = 1, L = 1
TL235	0.005 $\lambda$ , 51.58 $\Omega$	W = 1.651, L = 0.508	W = 65, L = 20
TL236	0.000 $\lambda$ , 8.31 $\Omega$	W = 16.510, L = 0.025	W = 650, L = 1
TL239		W1 = 20.320, W2 = 0.025, W3 = 20.320, W4 = 0.025	W1 = 800, W2 = 1, W3 = 800, W4 = 1
TL240, TL241	0.000 $\lambda$ , 6.86 $\Omega$	W = 20.320, L = 0.025	W = 800, L = 1

Reference Circuit (cont.)

Circuit Assembly Information

Test Fixture Part No. LTN/PTFB182503EF

Find Gerber files for this test fixture on the Infineon Web site at <http://www.infineon.com/rfpower>

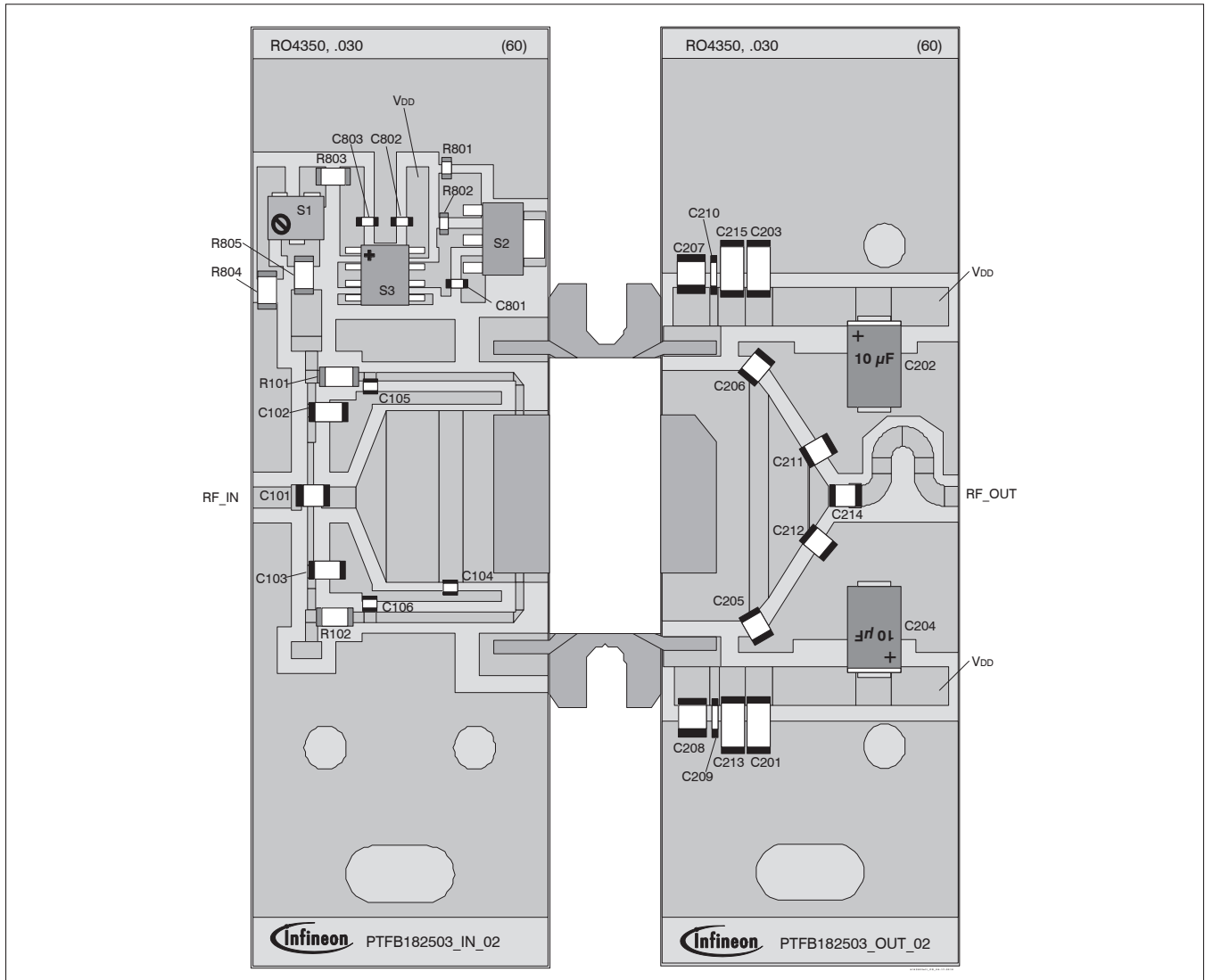

Reference circuit assembly diagram (not to scale)



## Reference Circuit (cont.)

Component	Description	Suggested Manufacturer	P/N
<b>Input</b>			
C101	Chip capacitor, 7.5 pF	ATC	ATC100B7R5BW500XB
C102, C103	Chip capacitor, 4.71 $\mu$ F	ATC	493-2372-2-ND
C104	Chip capacitor, 0.3 pF	ATC	ATC100A0R3BW150XB
C105, C106	Chip capacitor, 10 pF	ATC	ATC100A100FW150XB
C801, C802, C803	Capacitor, 1000 pF	Digi-Key	PCC1772CT-ND
R101, R102, R804, R805	Resistor, 10 $\Omega$	Digi-Key	P10ECT-ND
R801	Resistor, 1300 $\Omega$	Digi-Key	P1.3KGCT-ND
R802	Resistor, 1200 $\Omega$	Digi-Key	P1.2KGCT-ND
R803	Resistor, 100 $\Omega$	Digi-Key	P100ECT-ND
S1	Potentiometer, 2k $\Omega$	Digi-Key	3224W-202ECT-ND
S2	Transistor	Digi-Key	BCP5616TA-ND
S3	Voltage Regulator	Digi-Key	LM78L05ACM-ND
<b>Output</b>			
C201, C203	Chip capacitor, 0.1 $\mu$ F	Digi-Key	445-1411-2-ND
C202, C204	Capacitor, 10 $\mu$ F	Garrett Electronics	281M5002106K
C205, C206	Chip capacitor, 0.6 pF	ATC	ATC100B0R6BW500XB
C207, C208	Chip capacitor, 10 $\mu$ F	Digi-Key	587-1818-2-ND
C209, C210	Chip capacitor, 0.1 $\mu$ F	Digi-Key	399-1267-2-ND
C211, C212	Chip capacitor, 0.9 pF	ATC	ATC100B0R9BW500XB
C213, C215	Chip capacitor, 2.2 $\mu$ F	Digi-Key	445-1447-2-ND
C214	Chip capacitor, 10 pF	ATC	ATC100B100FW500XB

## Package Outline Specifications

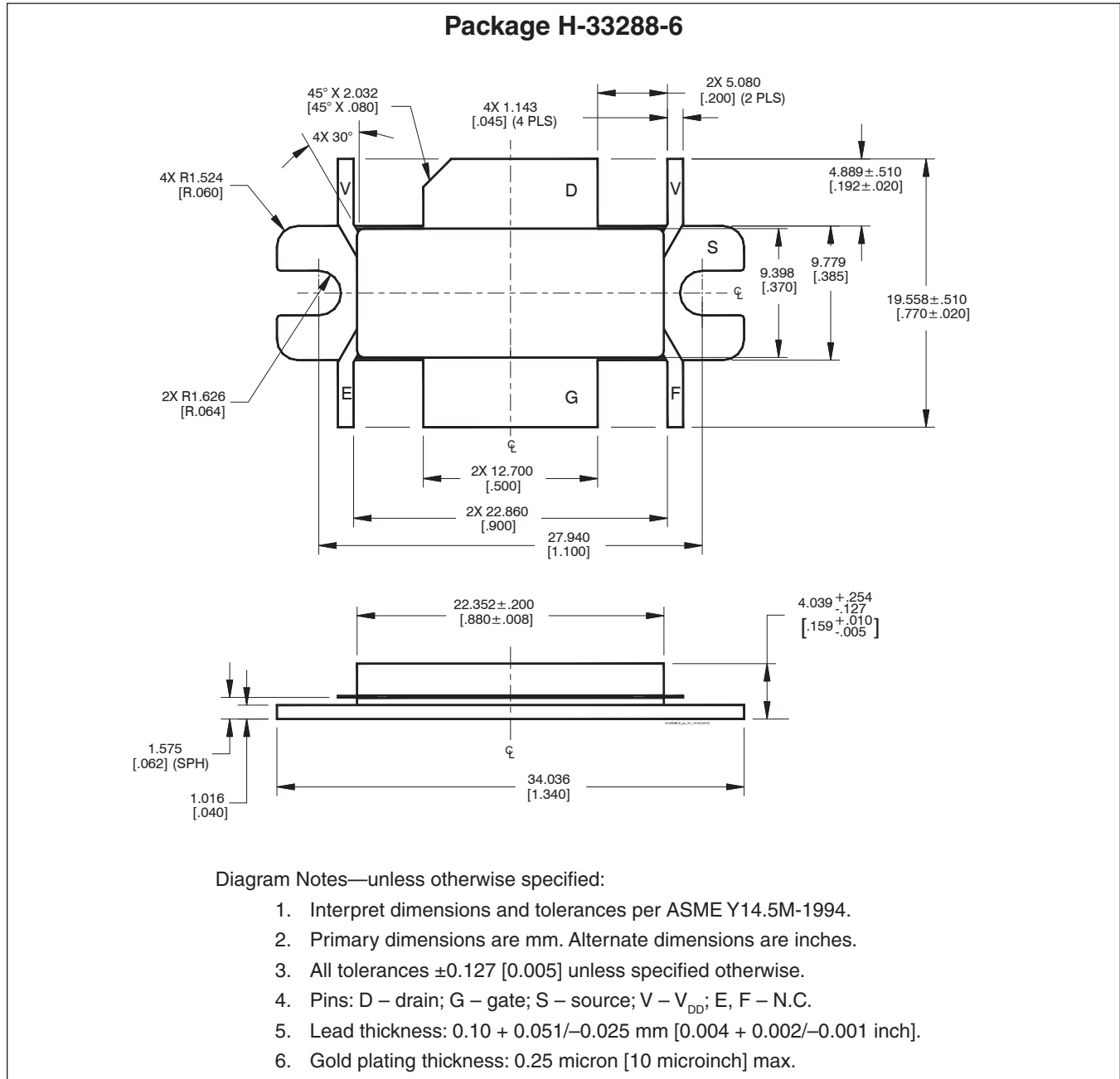

Package Outline Specifications (cont.)

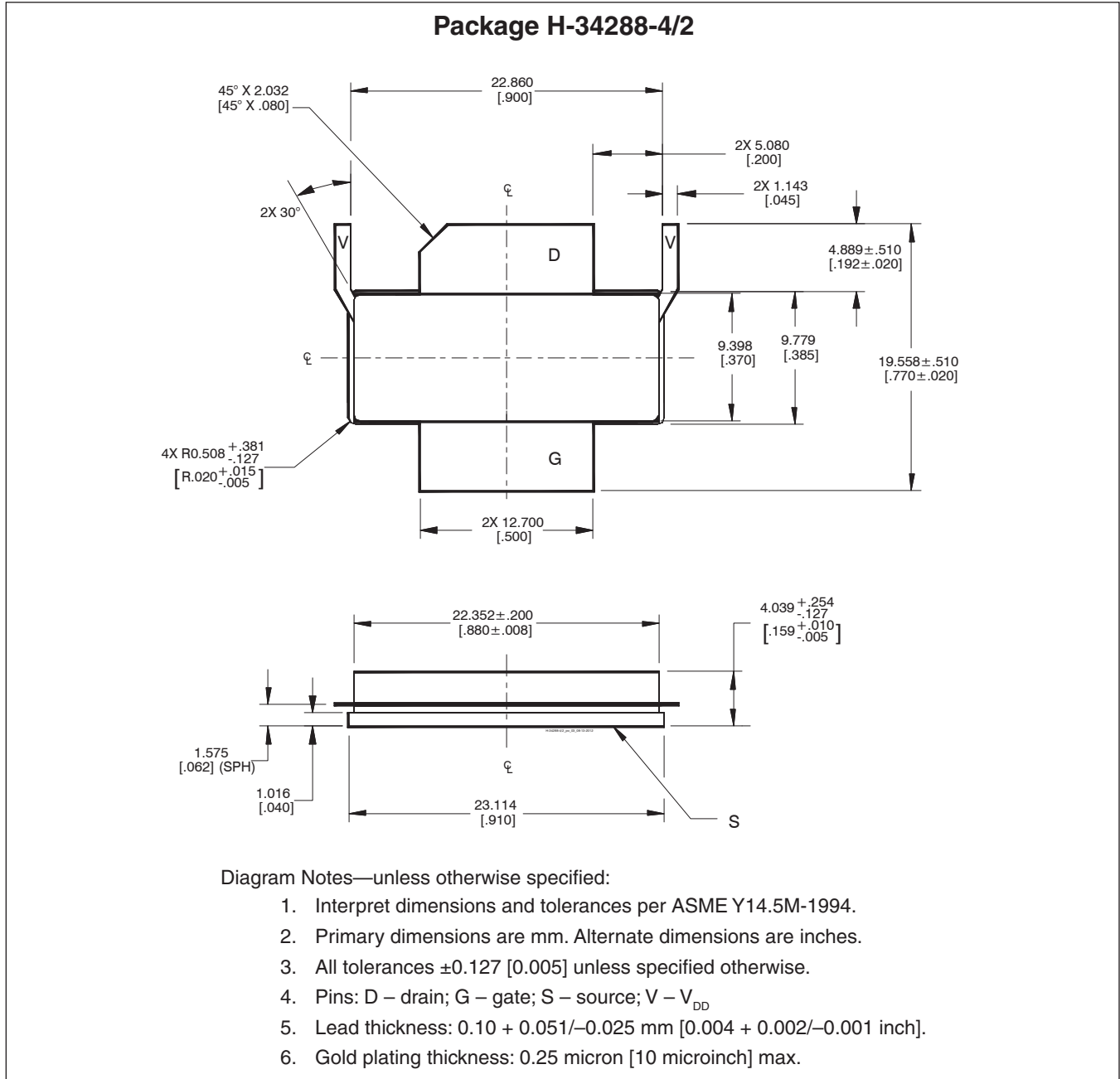

Find the latest and most complete information about products and packaging at the Infineon Internet page <http://www.infineon.com/rfpower>

<b>Revision History:</b>	2013-08-06	Data Sheet
Previous Version:	2012-10-03, Data Sheet	
Page	Subjects (major changes since last revision)	
2	Added operating voltage in Maximum Ratings table	

### We Listen to Your Comments

Any information within this document that you feel is wrong, unclear or missing at all?  
Your feedback will help us to continuously improve the quality of this document.  
Please send your proposal (including a reference to this document) to:

[highpowerRF@infineon.com](mailto:highpowerRF@infineon.com)

To request other information, contact us at:  
+1 877 465 3667 (1-877-GO-LDMOS) USA  
or +1 408 776 0600 International

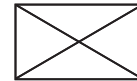

**Edition 2013-08-06**

**Published by**  
**Infineon Technologies AG**  
**81726 Munich, Germany**

**© 2009 Infineon Technologies AG**  
**All Rights Reserved.**

### Legal Disclaimer

The information given in this document shall in no event be regarded as a guarantee of conditions or characteristics. With respect to any examples or hints given herein, any typical values stated herein and/or any information regarding the application of the device, Infineon Technologies hereby disclaims any and all warranties and liabilities of any kind, including without limitation, warranties of non-infringement of intellectual property rights of any third party.

### Information

For further information on technology, delivery terms and conditions and prices, please contact the nearest Infineon Technologies Office ([www.infineon.com/rfpower](http://www.infineon.com/rfpower)).

### Warnings

Due to technical requirements, components may contain dangerous substances. For information on the types in question, please contact the nearest Infineon Technologies Office.

Infineon Technologies components may be used in life-support devices or systems only with the express written approval of Infineon Technologies, if a failure of such components can reasonably be expected to cause the failure of that life-support device or system or to affect the safety or effectiveness of that device or system. Life support devices or systems are intended to be implanted in the human body or to support and/or maintain and sustain and/or protect human life. If they fail, it is reasonable to assume that the health of the user or other persons may be endangered.