

# TL1451A

## DUAL PULSE-WIDTH-MODULATION CONTROL CIRCUITS

SLVS024E – FEBRUARY 1983 – REVISED NOVEMBER 1999

- Complete PWM Power Control Circuitry
- Completely Synchronized Operation
- Internal Undervoltage Lockout Protection
- Wide Supply Voltage Range
- Internal Short-Circuit Protection
- Oscillator Frequency . . . 500 kHz Max
- Variable Dead Time Provides Control Over Total Range
- Internal Regulator Provides a Stable 2.5-V Reference Supply
- Available in Q-Temp Automotive HighRel Automotive Applications Configuration Control / Print Support Qualification to Automotive Standards

### description

The TL1451A incorporates on a single monolithic chip all the functions required in the construction of two pulse-width-modulation (PWM) control circuits. Designed primarily for power-supply control, the TL1451A contains an on-chip 2.5-V regulator, two error amplifiers, an adjustable oscillator, two dead-time comparators, undervoltage lockout circuitry, and dual common-emitter output transistor circuits.

The uncommitted output transistors provide common-emitter output capability for each controller. The internal amplifiers exhibit a common-mode voltage range from 1.04 V to 1.45 V. The dead-time control (DTC) comparator has no offset unless externally altered and can provide 0% to 100% dead time. The on-chip oscillator can be operated by terminating RT and CT. During low  $V_{CC}$  conditions, the undervoltage lockout control circuit feature locks the outputs off until the internal circuitry is operational.

The TL1451AC is characterized for operation from  $-20^{\circ}\text{C}$  to  $85^{\circ}\text{C}$ . The TL1451AQ is characterized for operation from  $-40^{\circ}\text{C}$  to  $125^{\circ}\text{C}$ . The TL1451AM is characterized for operation from  $-55^{\circ}\text{C}$  to  $125^{\circ}\text{C}$ .

D, DB, N, NS, PW, OR J PACKAGE  
(TOP VIEW)

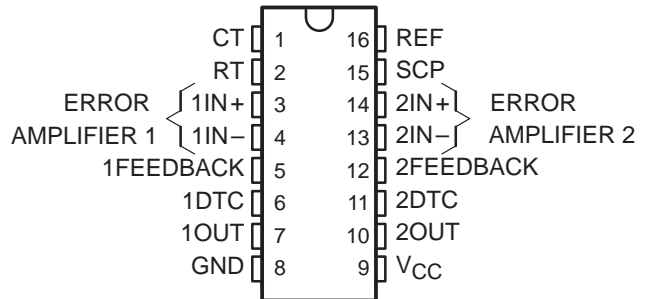

FK PACKAGE  
(TOP VIEW)

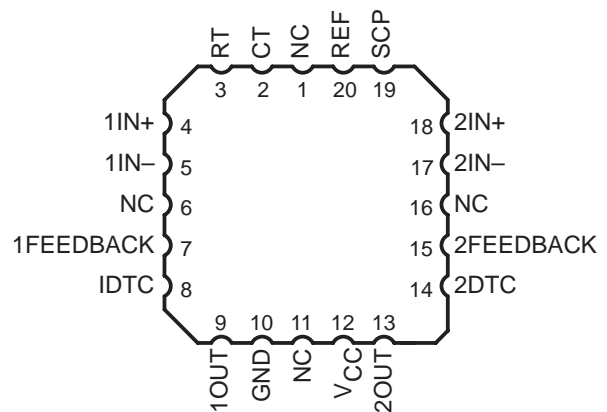

### AVAILABLE OPTIONS

T <sub>A</sub>	PACKAGED DEVICES						
	SMALL OUTLINE (D)	SMALL OUTLINE (DB) <sup>†</sup>	PLASTIC DIP (N)	SMALL OUTLINE (NS)	TSSOP (PW) <sup>†</sup>	CHIP CARRIER (FK)	CERAMIC DIP (J)
$-20^{\circ}\text{C}$ to $85^{\circ}\text{C}$	—	TL1451ACDB	TL1451ACN	TL1451ACNS	TL1451ACPW	—	—
$-40^{\circ}\text{C}$ to $125^{\circ}\text{C}$	TL1451AQD	—	—	—	—	—	—
$-55^{\circ}\text{C}$ to $125^{\circ}\text{C}$	—	—	—	—	—	TL1451AMFK	TL1451AMJ

<sup>†</sup> The DB and PW packages are only available left-end taped and reeled (add LE suffix, i.e., TL1451ACPWLE).



Please be aware that an important notice concerning availability, standard warranty, and use in critical applications of Texas Instruments semiconductor products and disclaimers thereto appears at the end of this data sheet.

PRODUCTION DATA information is current as of publication date. Products conform to specifications per the terms of Texas Instruments standard warranty. Production processing does not necessarily include testing of all parameters.



POST OFFICE BOX 655303 • DALLAS, TEXAS 75265

Copyright © 1999, Texas Instruments Incorporated  
On products compliant to MIL-PRF-38535, all parameters are tested unless otherwise noted. On all other products, production processing does not necessarily include testing of all parameters.

# TL1451A DUAL PULSE-WIDTH-MODULATION CONTROL CIRCUITS

SLVS024E – FEBRUARY 1983 – REVISED NOVEMBER 1999

## functional block diagram

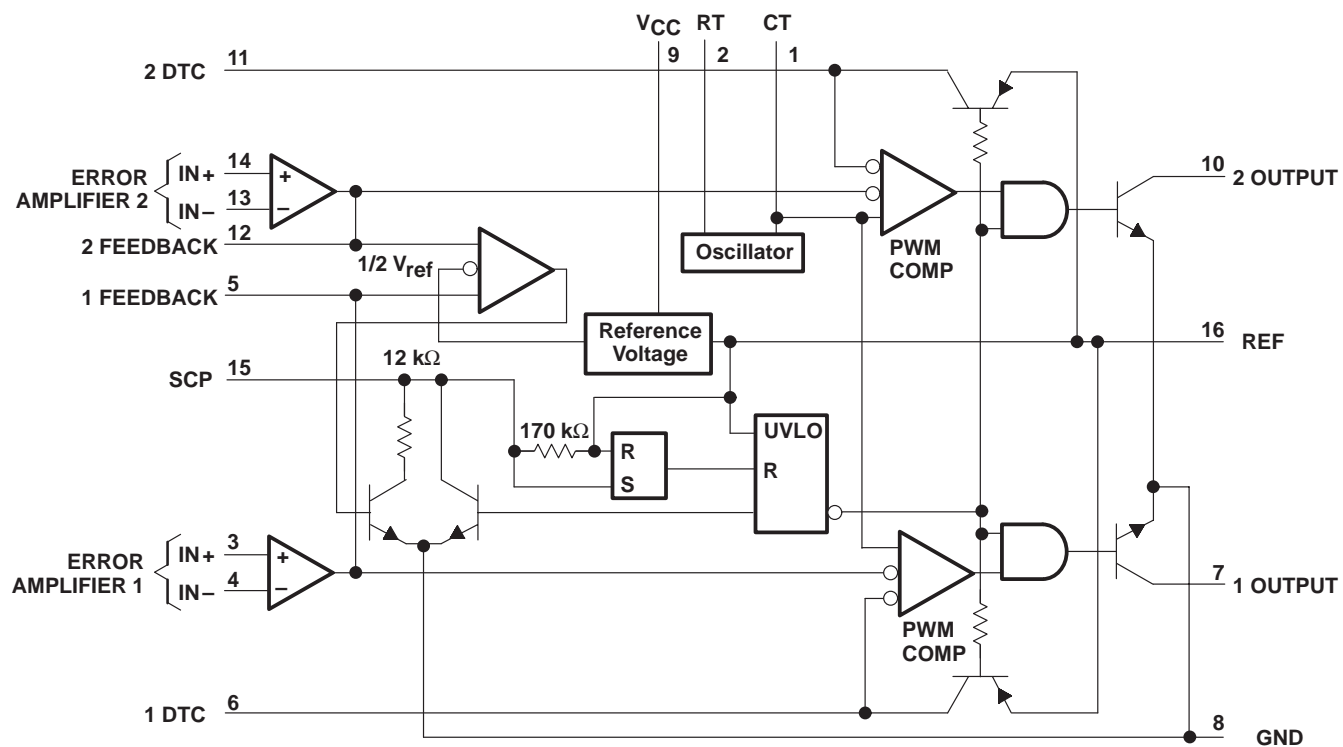

### COMPONENT COUNT

Resistors	65
Capacitors	8
Transistors	105
JFETs	18

# TL1451A

## DUAL PULSE-WIDTH-MODULATION CONTROL CIRCUITS

SLVS024E – FEBRUARY 1983 – REVISED NOVEMBER 1999

### absolute maximum ratings over operating free-air temperature range†

Supply voltage, $V_{CC}$ .....	51 V
Amplifier input voltage, $V_I$ .....	20 V
Collector output voltage, $V_O$ .....	51 V
Collector output current, $I_O$ .....	21 mA
Continuous power total dissipation .....	See Dissipation Rating Table
Operating free-air temperature range, $T_A$ C suffix .....	–20°C to 85°C
Q suffix .....	–40°C to 125°C
M suffix .....	–55°C to 125°C
Storage temperature range, $T_{stg}$ .....	–65°C to 150°C
Lead temperature 1,6 mm (1/16 inch) from case for 10 seconds .....	260°C

† Stresses beyond those listed under “absolute maximum ratings” may cause permanent damage to the device. These are stress ratings only, and functional operation of the device at these or any other conditions beyond those indicated under “recommended operating conditions” is not implied. Exposure to absolute-maximum-rated conditions for extended periods may affect device reliability.

**DISSIPATION RATING TABLE**

PACKAGE	$T_A \leq 25^\circ\text{C}$ POWER RATING	DERATING FACTOR ABOVE $T_A = 25^\circ\text{C}$	$T_A = 70^\circ\text{C}$ POWER RATING	$T_A = 85^\circ\text{C}$ POWER RATING	$T_A = 125^\circ\text{C}$ POWER RATING
D	1088 mW	8.7 mW/°C	696 mW	566 mW	218 mW
DB	775 mW	6.2 mW/°C	496 mW	403 mW	—
N	1000 mW	8.0 mW/°C	640 mW	520 mW	—
NS	500 mW	4.0 mW/°C	320 mW	260 mW	—
PW	838 mW	6.7 mW/°C	536 mW	436 mW	168 mW
FK	1375 mW	11.0 mW/°C	880 mW	715 mW	275 mW
J	1375 mW	11.0 mW/°C	880 mW	715 mW	275 mW

### recommended operating conditions

	MIN	MAX	UNIT
Supply voltage, $V_{CC}$	3.6	50	V
Amplifier input voltage, $V_I$	1.05	1.45	V
Collector output voltage, $V_O$		50	V
Collector output current, $I_O$		20	mA
Current into feedback terminal		45	μA
Feedback resistor, $R_F$	100		kΩ
Timing capacitor, $C_T$	150	15000	pF
Timing resistor, $R_T$	5.1	100	kΩ
Oscillator frequency	1	500	kHz
Operating free-air temperature, $T_A$	C suffix	–20	85
	Q suffix	–40	125
	M suffix	–55	125
			°C



# TL1451A

## DUAL PULSE-WIDTH-MODULATION CONTROL CIRCUITS

SLVS024E – FEBRUARY 1983 – REVISED NOVEMBER 1999

electrical characteristics over recommended operating free-air temperature range,  $V_{CC} = 6\text{ V}$ ,  $f = 200\text{ kHz}$  (unless otherwise noted)

### reference section

PARAMETER	TEST CONDITIONS	TL1451AC			UNIT
		MIN	TYP†	MAX	
Output voltage (pin 16)	$I_O = 1\text{ mA}$	2.4	2.5	2.6	V
Output voltage change with temperature	$T_A = -20^\circ\text{C}$ to $25^\circ\text{C}$		-0.1%	$\pm 1\%$	
	$T_A = 25^\circ\text{C}$ to $85^\circ\text{C}$		-0.2%	$\pm 1\%$	
Input voltage regulation	$V_{CC} = 3.6\text{ V}$ to $40\text{ V}$		2	12.5	mV
Output voltage regulation	$I_O = 0.1\text{ mA}$ to $1\text{ mA}$		1	7.5	mV
Short-circuit output current	$V_O = 0$	3	10	30	mA

† All typical values are at  $T_A = 25^\circ\text{C}$ .

### undervoltage lockout section

PARAMETER	TEST CONDITIONS	TL1451AC			UNIT
		MIN	TYP†	MAX	
Upper threshold voltage ( $V_{CC}$ )	$I_{O(\text{ref})} = 0.1\text{ mA}$ , $T_A = 25^\circ\text{C}$		2.72		V
Lower threshold voltage ( $V_{CC}$ )			2.6		V
Hysteresis ( $V_{CC}$ )		80	120		mV
Reset threshold voltage ( $V_{CC}$ )		1.5	1.9		V

† All typical values are at  $T_A = 25^\circ\text{C}$ .

### short-circuit protection control section

PARAMETER	TEST CONDITIONS	TL1451AC			UNIT
		MIN	TYP†	MAX	
Input threshold voltage (SCP)	$T_A = 25^\circ\text{C}$	0.65	0.7	0.75	V
Standby voltage (SCP)	No pullup	140	185	230	mV
Latched input voltage (SCP)	No pullup		60	120	mV
Input (source) current	$V_I = 0.7\text{ V}$ , $T_A = 25^\circ\text{C}$	-10	-15	-20	$\mu\text{A}$
Comparator threshold voltage (FEEDBACK)			1.18		V

† All typical values are at  $T_A = 25^\circ\text{C}$ .

### oscillator section

PARAMETER	TEST CONDITIONS	TL1451C			UNIT
		MIN	TYP†	MAX	
Frequency	$C_T = 330\text{ pF}$ , $R_T = 10\text{ k}\Omega$		200		kHz
Standard deviation of frequency	$C_T = 330\text{ pF}$ , $R_T = 10\text{ k}\Omega$		10%		
Frequency change with voltage	$V_{CC} = 3.6\text{ V}$ to $40\text{ V}$		1%		
Frequency change with temperature	$T_A = -20^\circ\text{C}$ to $25^\circ\text{C}$		-0.4%	$\pm 2\%$	
	$T_A = 25^\circ\text{C}$ to $85^\circ\text{C}$		-0.2%	$\pm 2\%$	

† All typical values are at  $T_A = 25^\circ\text{C}$ .



# TL1451A

## DUAL PULSE-WIDTH-MODULATION CONTROL CIRCUITS

SLVS024E – FEBRUARY 1983 – REVISED NOVEMBER 1999

### dead-time control section

PARAMETER	TEST CONDITIONS	TL1451AC			UNIT
		MIN	TYP†	MAX	
Input bias current (DTC)				1	μA
Latch mode (source) current (DTC)	T <sub>A</sub> = 25°C	-80	-145		μA
Latched input voltage (DTC)	I <sub>O</sub> = 40 μA	2.3			V
Input threshold voltage at f = 10 kHz (DTC)	Zero duty cycle		2.05	2.25	V
	Maximum duty cycle	1.2	1.45		

† All typical values are at T<sub>A</sub> = 25°C.

### error-amplifier section

PARAMETER	TEST CONDITIONS	TL1451AC			UNIT
		MIN	TYP†	MAX	
Input offset voltage	V <sub>O</sub> (FEEDBACK) = 1.25 V			±6	mV
Input offset current	V <sub>O</sub> (FEEDBACK) = 1.25 V			±100	nA
Input bias current	V <sub>O</sub> (FEEDBACK) = 1.25 V		160	500	nA
Common-mode input voltage range	V <sub>CC</sub> = 3.6 V to 40 V	1.05 to 1.45			V
Open-loop voltage amplification	R <sub>F</sub> = 200 kΩ	70	80		dB
Unity-gain bandwidth			1.5		MHz
Common-mode rejection ratio		60	80		dB
Positive output voltage swing				V <sub>ref</sub> -0.1	V
Negative output voltage swing				1	V
Output (sink) current (FEEDBACK)	V <sub>ID</sub> = -0.1 V, V <sub>O</sub> = 1.25 V	0.5	1.6		mA
Output (source) current (FEEDBACK)	V <sub>ID</sub> = 0.1 V, V <sub>O</sub> = 1.25 V	-45	-70		μA

† All typical values are at T<sub>A</sub> = 25°C.

### output section

PARAMETER	TEST CONDITIONS	TL1451AC			UNIT
		MIN	TYP†	MAX	
Collector off-state current	V <sub>O</sub> = 50 V			10	μA
Output saturation voltage	I <sub>O</sub> = 10 mA		1.2	2	V
Short-circuit output current	V <sub>O</sub> = 6 V		90		mA

† All typical values are at T<sub>A</sub> = 25°C.

### pwm comparator section

PARAMETER	TEST CONDITIONS	TL1451AC			UNIT
		MIN	TYP†	MAX	
Input threshold voltage at f = 10 kHz (FEEDBACK)	Zero duty cycle		2.05	2.25	V
	Maximum duty cycle	1.2	1.45		

† All typical values are at T<sub>A</sub> = 25°C.

### total device

PARAMETER	TEST CONDITIONS	TL1451AC			UNIT
		MIN	TYP†	MAX	
Standby supply current	Off-state		1.3	1.8	mA
Average supply current	R <sub>T</sub> = 10 kΩ		1.7	2.4	mA

† All typical values are at T<sub>A</sub> = 25°C.



# TL1451A

## DUAL PULSE-WIDTH-MODULATION CONTROL CIRCUITS

SLVS024E – FEBRUARY 1983 – REVISED NOVEMBER 1999

electrical characteristics over recommended operating free-air temperature range,  $V_{CC} = 6\text{ V}$ ,  $f = 200\text{ kHz}$  (unless otherwise noted)

### reference section

PARAMETER	TEST CONDITIONS		TL1451AQ, TL1451AM			UNIT
			MIN	TYP†	MAX	
Output voltage (pin 16)	$I_O = 1\text{ mA}$	$T_A = 25^\circ\text{C}$	2.40	2.50	2.60	V
		$T_A = \text{MIN and } 125^\circ\text{C}$	2.35	2.46	2.65	
Output voltage change with temperature			-0.63%		*±4%	
Input voltage regulation	$V_{CC} = 3.6\text{ V to } 40\text{ V}$	$T_A = 25^\circ\text{C}$		2.0	12.5	mV
		$T_A = 125^\circ\text{C}$		0.7	15	
		$T_A = \text{MIN}$		0.3	30	
Output voltage regulation	$I_O = 0.1\text{ mA to } 1\text{ mA}$	$T_A = 25^\circ\text{C}$		1.0	7.5	mV
		$T_A = 125^\circ\text{C}$		0.3	14	
		$T_A = \text{MIN}$		0.3	20	
Short-circuit output current	$V_O = 0$		3	10	30	mA

\*These parameters are not production tested.

† All typical values are at  $T_A = 25^\circ\text{C}$  unless otherwise indicated.

### undervoltage lockout section

PARAMETER	TEST CONDITIONS		TL1451AQ, TL1451AM			UNIT
			MIN	TYP†	MAX	
Upper threshold voltage ( $V_{CC}$ )		$T_A = 25^\circ\text{C}$		2.72		V
		$T_A = 125^\circ\text{C}$		1.70		
		$T_A = \text{MIN}$		3.15		
Lower threshold voltage ( $V_{CC}$ )		$T_A = 25^\circ\text{C}$		2.60		V
		$T_A = 125^\circ\text{C}$		1.65		
		$T_A = \text{MIN}$		3.09		
Hysteresis ( $V_{CC}$ )		$T_A = 25^\circ\text{C}$	80	120		mV
		$T_A = 125^\circ\text{C}$	10	50		
		$T_A = \text{MIN}$	10	60		
Reset threshold voltage ( $V_{CC}$ )		$T_A = 25^\circ\text{C}$		1.50		V
		$T_A = 125^\circ\text{C}$		0.95		
		$T_A = \text{MIN}$		1.50		

† All typical values are at  $T_A = 25^\circ\text{C}$  unless otherwise indicated.



# TL1451A

## DUAL PULSE-WIDTH-MODULATION CONTROL CIRCUITS

SLVS024E – FEBRUARY 1983 – REVISED NOVEMBER 1999

### short-circuit protection control section

PARAMETER	TEST CONDITIONS	TL1451AQ, TL1451AM			UNIT
		MIN	TYP†	MAX	
Input threshold voltage (SCP)	$T_A = 25^\circ\text{C}$	650	700	750	mV
	$T_A = 125^\circ\text{C}$	400	478	550	
	$T_A = \text{MIN}$	800	880	950	
Standby voltage (SCP)		140	185	230	mV
Latched input voltage (SCP)	$T_A = 25^\circ\text{C}$		60	120	mV
	$T_A = 125^\circ\text{C}$		70	120	
	$T_A = \text{MIN}$		60	120	
Equivalent timing resistance			170		k $\Omega$
Comparator threshold voltage (FEEDBACK)			1.18		V

† All typical values are at  $T_A = 25^\circ\text{C}$  unless otherwise indicated.

### oscillator section

PARAMETER	TEST CONDITIONS	TL1451AQ, TL1451AM			UNIT
		MIN	TYP†	MAX	
Frequency	$C_T = 330 \text{ pF}$ , $R_T = 10 \text{ k}\Omega$	$T_A = 25^\circ\text{C}$	200		kHz
		$T_A = 125^\circ\text{C}$	195		
		$T_A = \text{MIN}$	193		
Standard deviation of frequency	$C_T = 330 \text{ pF}$ , $R_T = 10 \text{ k}\Omega$		2%		
Frequency change with voltage	$V_{CC} = 3.6 \text{ V to } 40 \text{ V}$	$T_A = 25^\circ\text{C}$	1%		
		$T_A = 125^\circ\text{C}$	1%		
		$T_A = \text{MIN}$	3%		
Frequency change with temperature			1.37%	$\pm 10\%$	

\*These parameters are not production tested.

† All typical values are at  $T_A = 25^\circ\text{C}$  unless otherwise indicated.

### dead-time control section

PARAMETER	TEST CONDITIONS	TL1451AQ, TL1451AM			UNIT
		MIN	TYP†	MAX	
Input bias current (DTC)	$T_A = 25^\circ\text{C}$			1	$\mu\text{A}$
	$T_A = \text{MIN and } 125^\circ\text{C}$			3	
Latch mode (source) current (DTC)		-80	-145		$\mu\text{A}$
Latched input voltage (DTC)	$T_A = 25^\circ\text{C}$	2.30		V	
	$T_A = 125^\circ\text{C}$	2.22	2.32		
	$T_A = \text{MIN}$	2.28	2.40		
Input threshold voltage at $f = 10 \text{ kHz}$ (DTC)	Zero duty cycle		2.05	*2.25	V
	Maximum duty cycle	*1.20	1.45		

\*These parameters are not production tested.

† All typical values are at  $T_A = 25^\circ\text{C}$  unless otherwise indicated.



# TL1451A DUAL PULSE-WIDTH-MODULATION CONTROL CIRCUITS

SLVS024E – FEBRUARY 1983 – REVISED NOVEMBER 1999

## error-amplifier section

PARAMETER	TEST CONDITIONS	TL1451AQ, TL1451AM			UNIT
		MIN	TYP†	MAX	
Input offset voltage	$V_O$ (FEEDBACK) = 1.25 V	$T_A = 25^\circ\text{C}$	±6		mV
		$T_A = 125^\circ\text{C}$	±10		
		$T_A = \text{MIN}$	±12		
Input offset current	$V_O$ (FEEDBACK) = 1.25 V	$T_A = 25^\circ\text{C}$	±100		nA
		$T_A = 125^\circ\text{C}$	±100		
		$T_A = \text{MIN}$	±200		
Input bias current	$V_O$ (FEEDBACK) = 1.25 V	$T_A = 25^\circ\text{C}$	160	500	nA
		$T_A = 125^\circ\text{C}$	100	500	
		$T_A = \text{MIN}$	142	700	
Common-mode input voltage range	$V_{CC} = 3.6 \text{ V to } 40 \text{ V}$	1.05 to 1.45			V
Open-loop voltage amplification	$R_F = 200 \text{ k}\Omega$	$T_A = 25^\circ\text{C}$	70	80	dB
		$T_A = 125^\circ\text{C}$	70	80	
		$T_A = \text{MIN}$	64	80	
Unity-gain bandwidth			1.5		MHz
Common-mode rejection ratio		60	80		dB
Positive output voltage swing		2			V
Negative output voltage swing				1	V
Output (sink) current (FEEDBACK)	$V_{ID} = -0.1 \text{ V}, V_O = 1.25 \text{ V}$	$T_A = 25^\circ\text{C}$	0.5	1.6	mA
		$T_A = 125^\circ\text{C}$	0.4	1.8	
		$T_A = \text{MIN}$	0.3	1.7	
Output (source) current (FEEDBACK)	$V_{ID} = 0.1 \text{ V}, V_O = 1.25 \text{ V}$	$T_A = 25^\circ\text{C}$	-45	-70	μA
		$T_A = 125^\circ\text{C}$	-25	-50	
		$T_A = \text{MIN}$	-15	-70	

† All typical values are at  $T_A = 25^\circ\text{C}$  unless otherwise indicated.

## output section

PARAMETER	TEST CONDITIONS	TL1451AQ, TL1451AM			UNIT
		MIN	TYP†	MAX	
Collector off-state current	$V_O = 50 \text{ V}$			10	μA
Output saturation voltage	$T_A = 25^\circ\text{C}$		1.20	2.0	V
	$T_A = 125^\circ\text{C}$		1.60	2.4	
	$T_A = \text{MIN}$		1.36	2.2	
Short-circuit output current	$V_O = 6 \text{ V}$		90		mA

† All typical values are at  $T_A = 25^\circ\text{C}$  unless otherwise indicated.

## pwm comparator section

PARAMETER	TEST CONDITIONS	TL1451AQ, TL1451AM			UNIT
		MIN	TYP†	MAX	
Input threshold voltage at $f = 10 \text{ kHz}$ (FEEDBACK)	Zero duty cycle		2.05	*2.25	V
	Maximum duty cycle	*1.20	1.45		

\*These parameters are not production tested.

† All typical values are at  $T_A = 25^\circ\text{C}$  unless otherwise indicated.





# TL1451A DUAL PULSE-WIDTH-MODULATION CONTROL CIRCUITS

SLVS024E – FEBRUARY 1983 – REVISED NOVEMBER 1999

## total device

PARAMETER	TEST CONDITIONS	TL1451AQ, TL1451AM			UNIT
		MIN	TYP†	MAX	
Standby supply current	Off-state		1.3	1.8	mA
Average supply current	$R_T = 10\text{ k}\Omega$		1.7	2.4	mA

† All typical values are at  $T_A = 25^\circ\text{C}$  unless otherwise indicated.

## PARAMETER MEASUREMENT INFORMATION

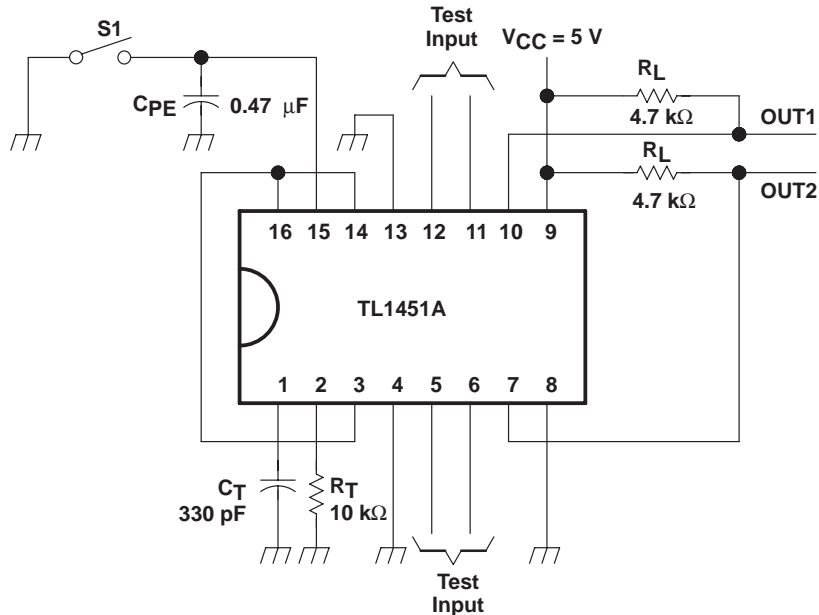
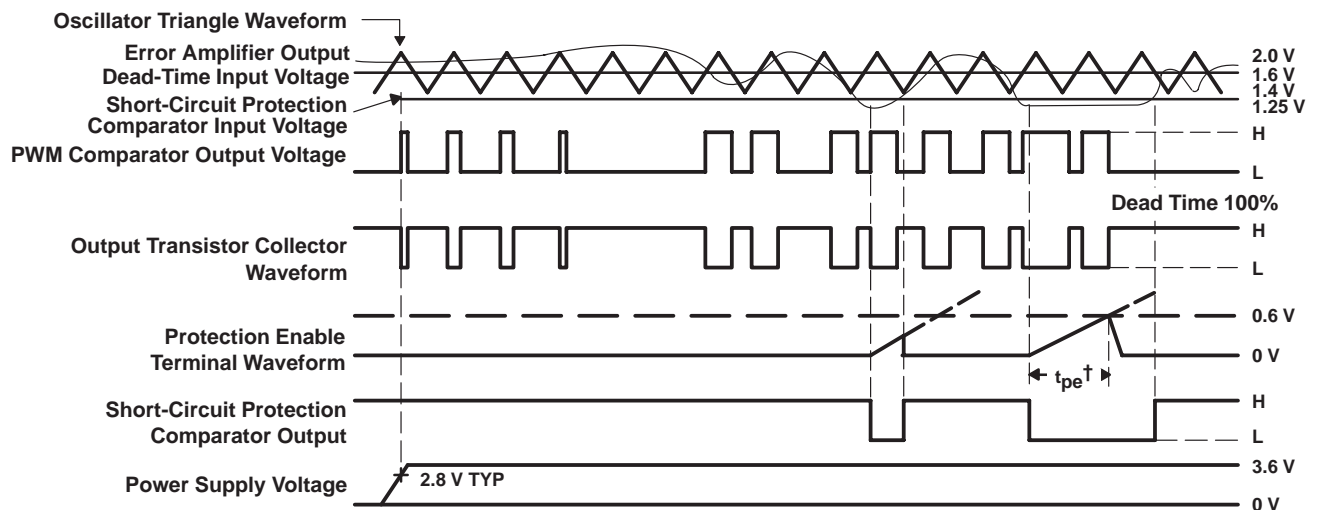

Figure 1. Test Circuit



† Protection Enable Time,  $t_{pe} = (0.051 \times 10^6 \times C_{pe})$  in seconds

Figure 2. TL1451A Timing Diagram



# TL1451A DUAL PULSE-WIDTH-MODULATION CONTROL CIRCUITS

SLVS024E – FEBRUARY 1983 – REVISED NOVEMBER 1999

## TYPICAL CHARACTERISTICS

TRIANGLE OSCILLATOR FREQUENCY  
vs  
TIMING RESISTANCE

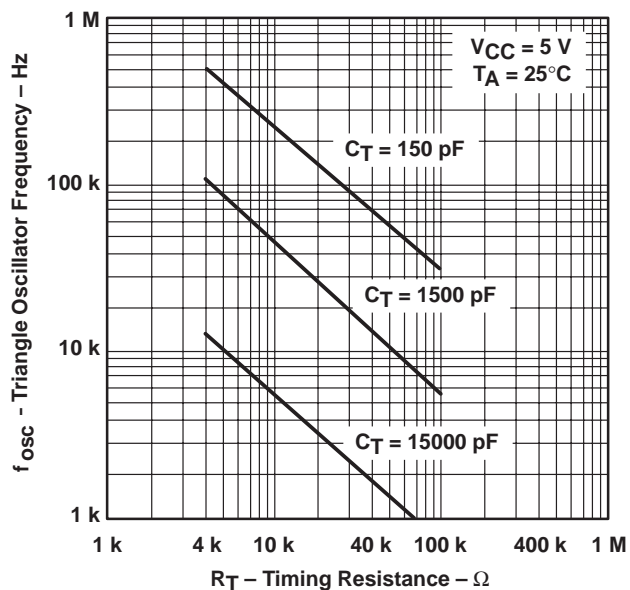

Figure 3

OSCILLATOR FREQUENCY VARIATION  
vs  
FREE-AIR TEMPERATURE

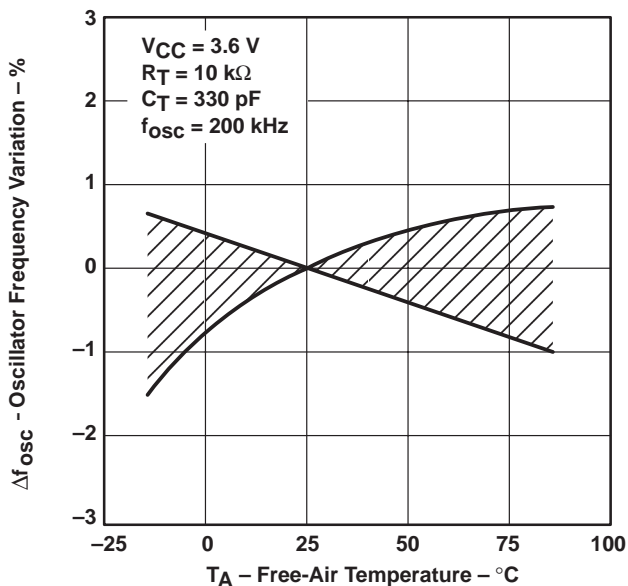

Figure 4

TRIANGLE WAVEFORM SWING VOLTAGE  
vs  
TIMING CAPACITANCE

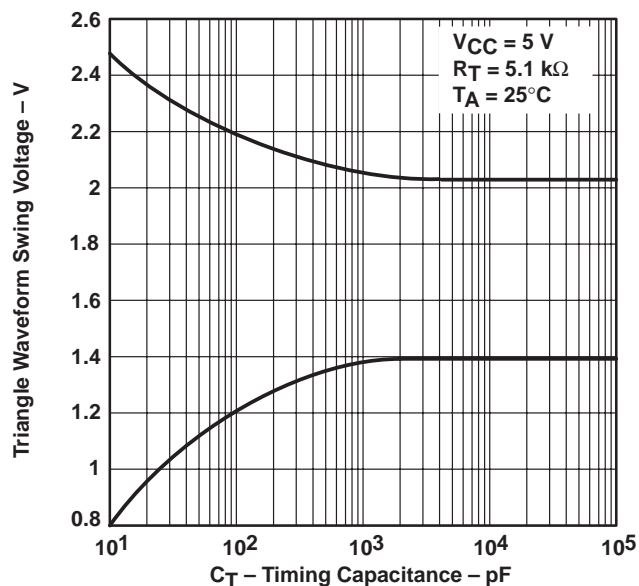

Figure 5

TRIANGLE WAVEFORM PERIOD  
vs  
TIMING CAPACITANCE

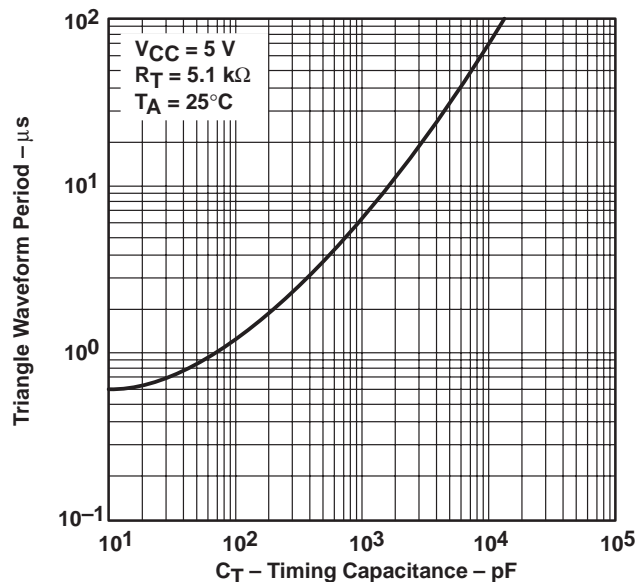

Figure 6



TYPICAL CHARACTERISTICS

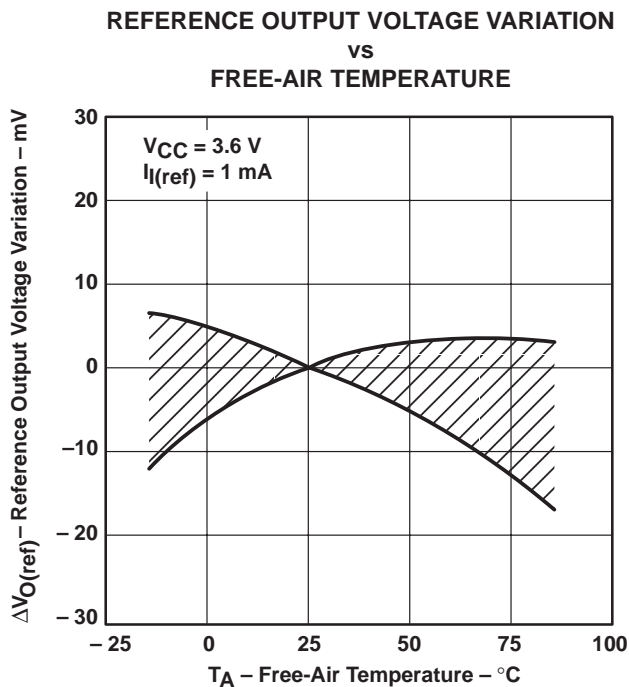

Figure 7

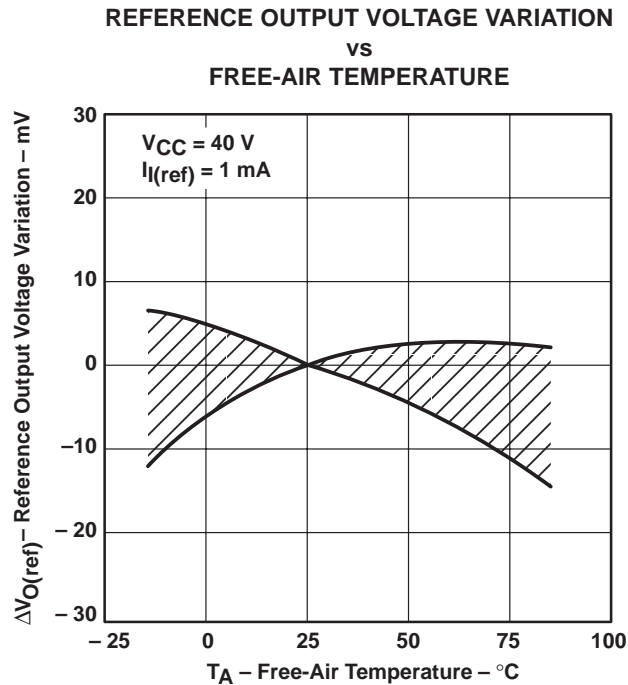

Figure 8

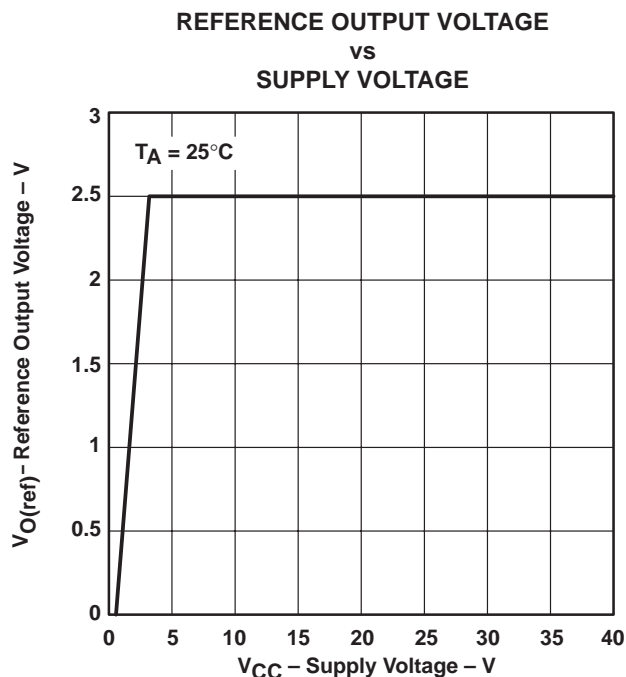

Figure 9

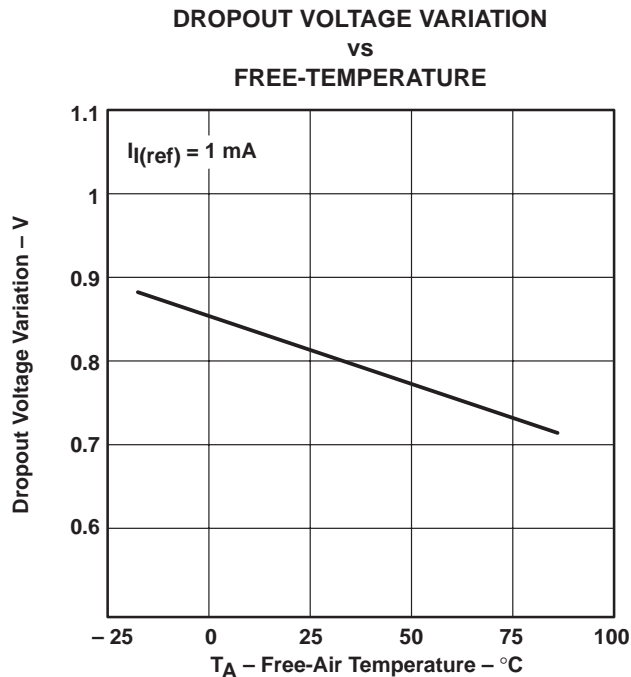

Figure 10

# TL1451A DUAL PULSE-WIDTH-MODULATION CONTROL CIRCUITS

SLVS024E – FEBRUARY 1983 – REVISED NOVEMBER 1999

## TYPICAL CHARACTERISTICS

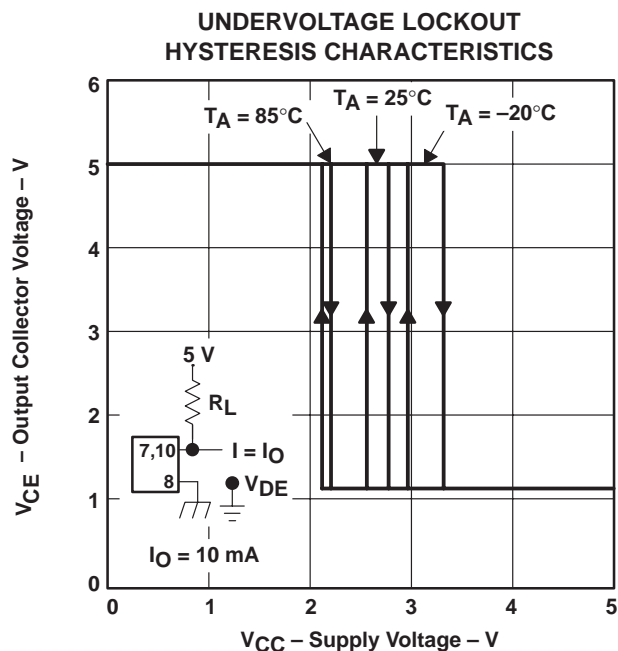

Figure 11

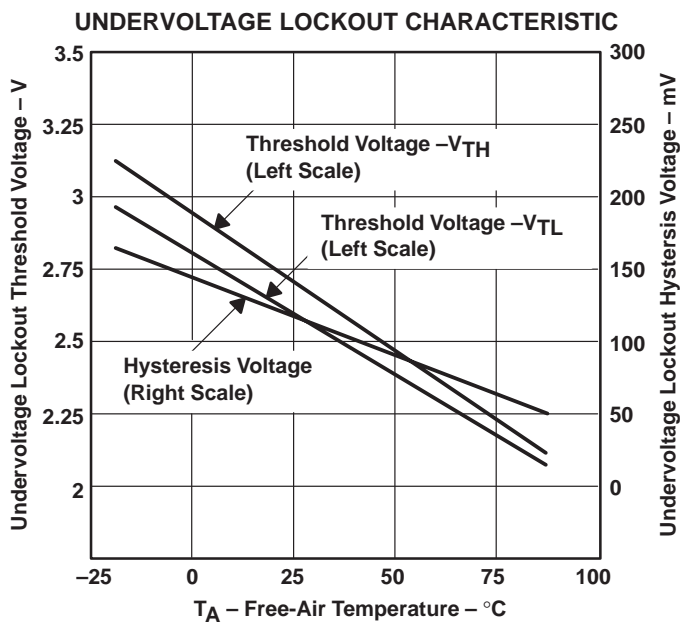

Figure 12

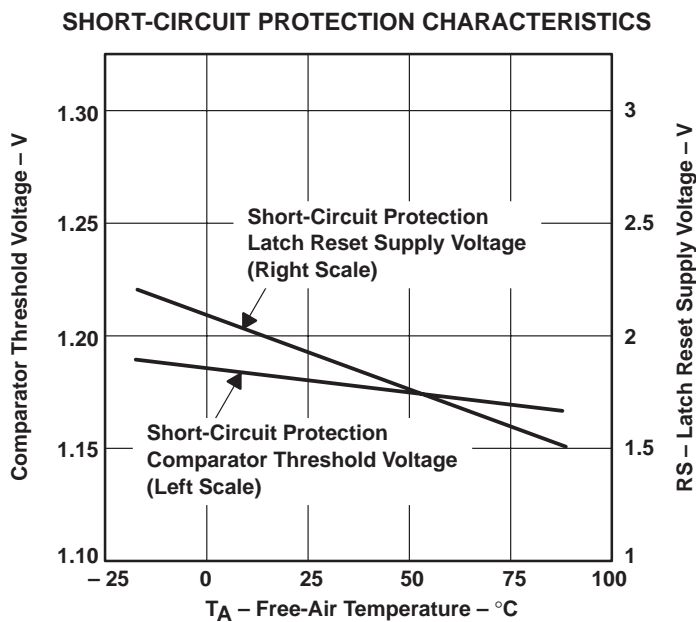

Figure 13

TYPICAL CHARACTERISTICS

PROTECTION ENABLE TIME  
 VS  
 PROTECTION ENABLE CAPACITANCE

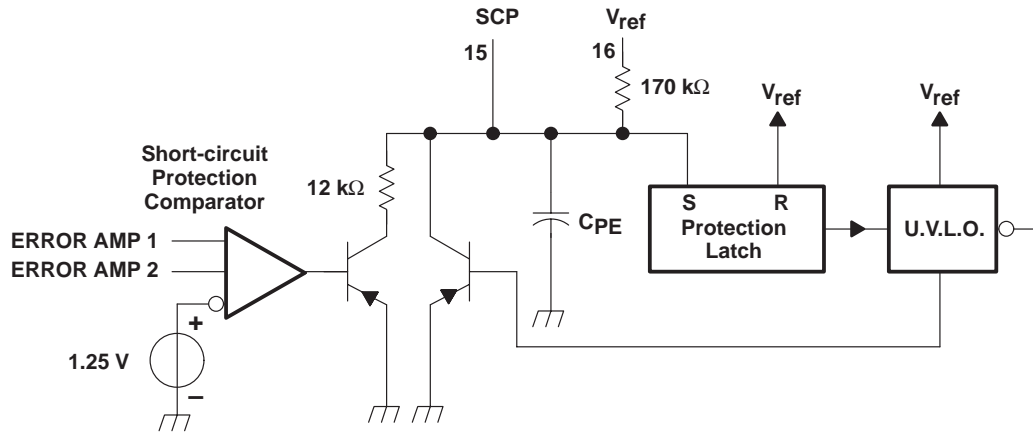
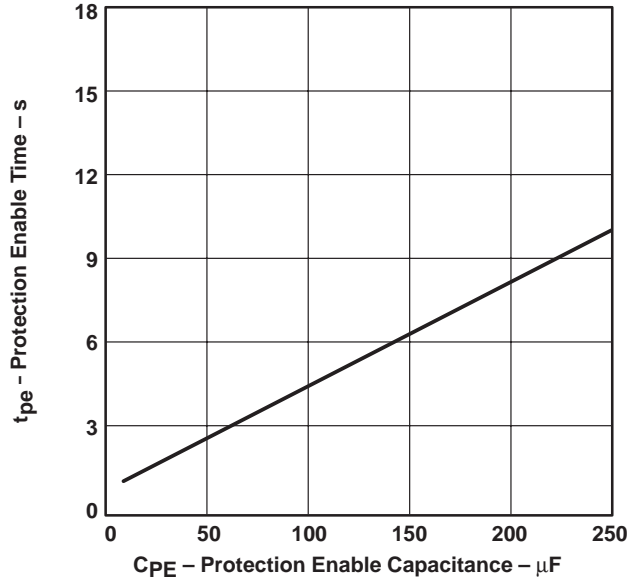

Figure 14

# TL1451A DUAL PULSE-WIDTH-MODULATION CONTROL CIRCUITS

SLVS024E – FEBRUARY 1983 – REVISED NOVEMBER 1999

## TYPICAL CHARACTERISTICS

**ERROR AMP MAXIMUM OUTPUT VOLTAGE SWING  
VS  
FREQUENCY**

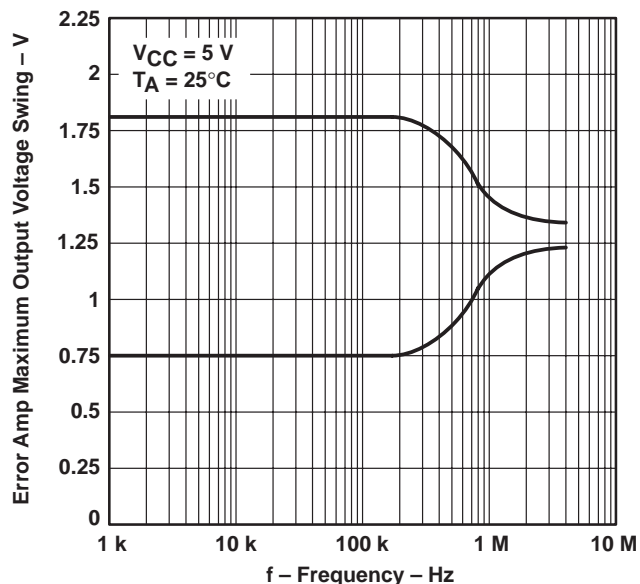

Figure 15

**OPEN-LOOP VOLTAGE AMPLIFICATION  
VS  
FREQUENCY**

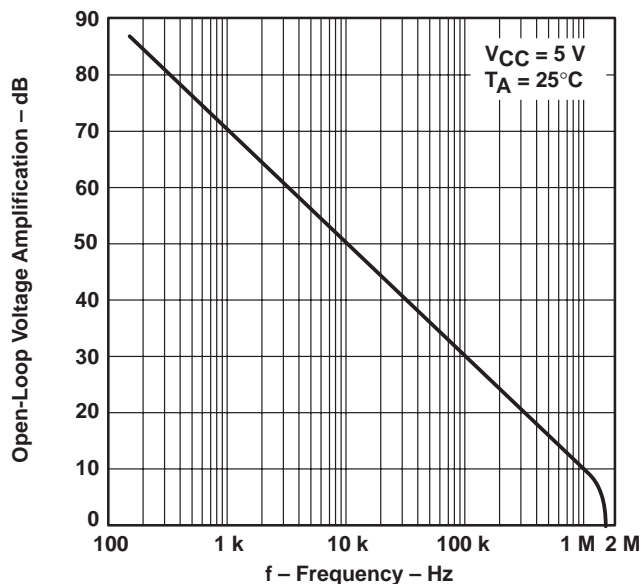

Figure 16

**GAIN (AMPLIFIER IN  
UNITY-GAIN CONFIGURATION)  
VS  
FREQUENCY**

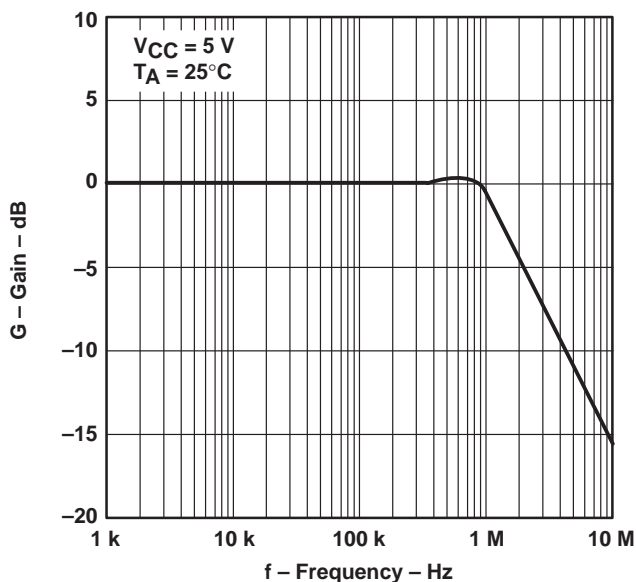
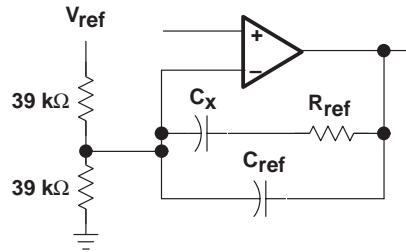
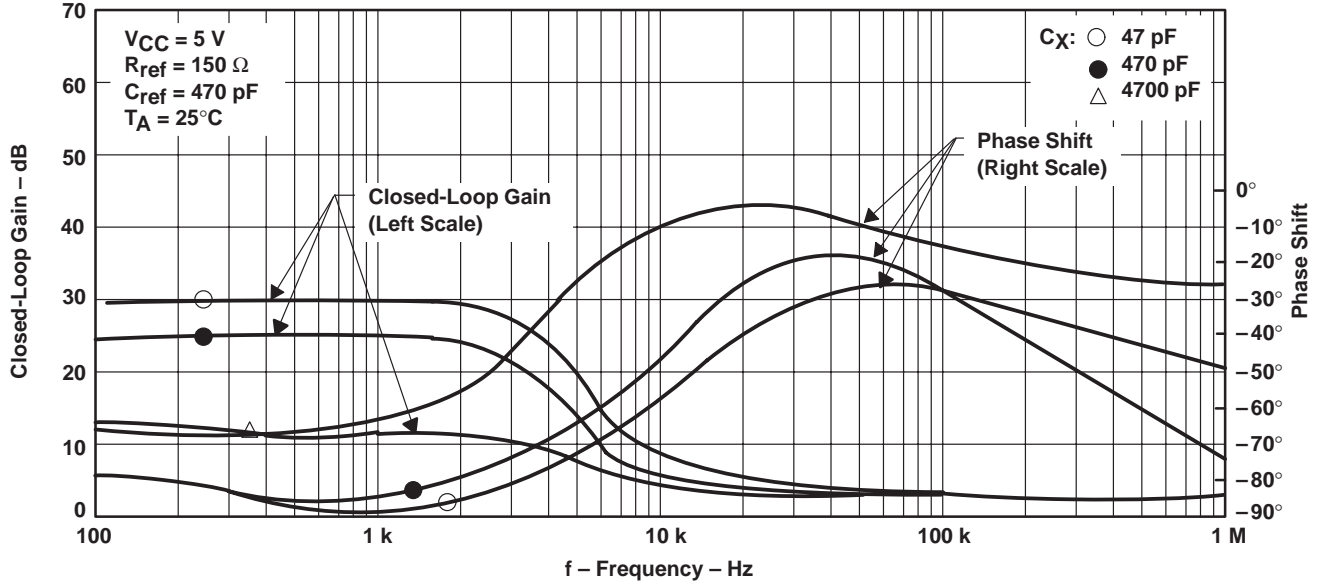

Figure 17

TYPICAL CHARACTERISTICS

CLOSED-LOOP GAIN AND PHASE SHIFT  
 VS  
 FREQUENCY



Test Circuit

Figure 18

# TL1451A DUAL PULSE-WIDTH-MODULATION CONTROL CIRCUITS

SLVS024E – FEBRUARY 1983 – REVISED NOVEMBER 1999

## TYPICAL CHARACTERISTICS

### CLOSED-LOOP GAIN AND PHASE SHIFT vs FREQUENCY

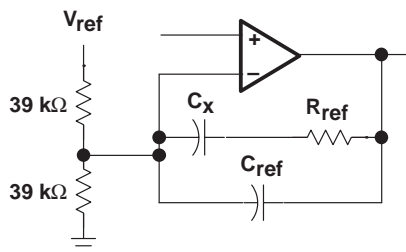
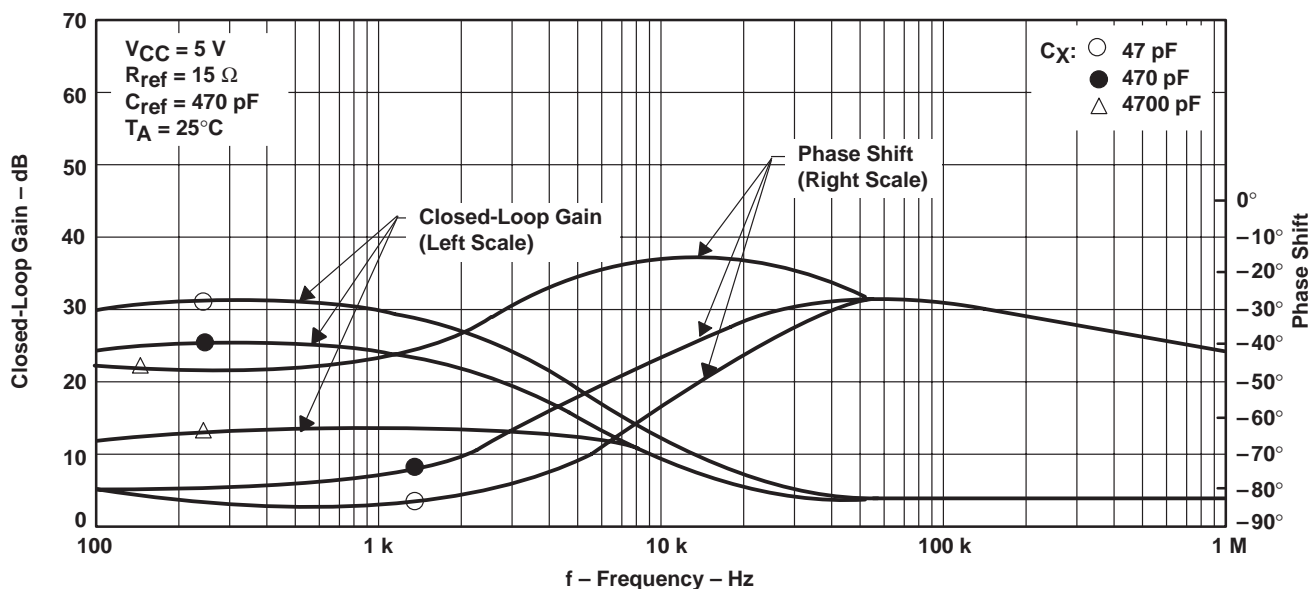

Test Circuit

Figure 19



TYPICAL CHARACTERISTICS

CLOSED-LOOP GAIN AND PHASE SHIFT  
 VS  
 FREQUENCY

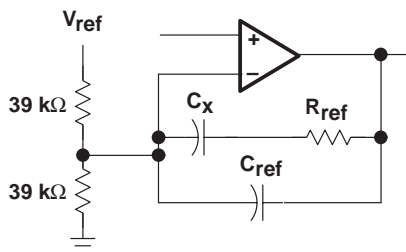
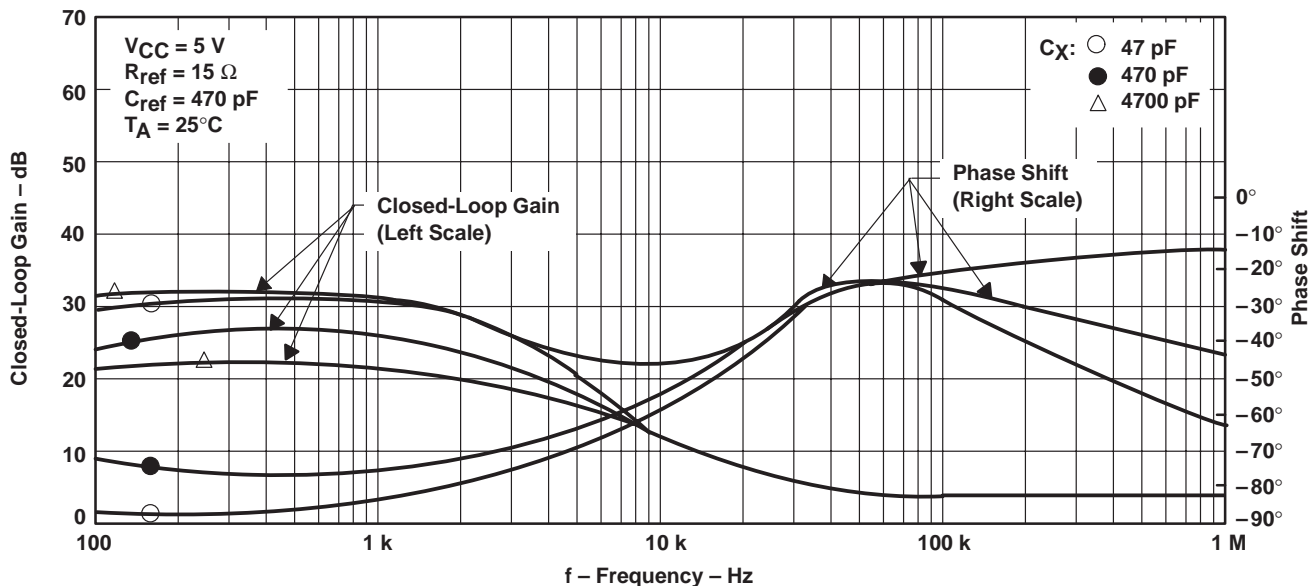

Test Circuit

Figure 20

# TL1451A DUAL PULSE-WIDTH-MODULATION CONTROL CIRCUITS

SLVS024E – FEBRUARY 1983 – REVISED NOVEMBER 1999

## TYPICAL CHARACTERISTICS

### CLOSED-LOOP GAIN AND PHASE SHIFT vs FREQUENCY

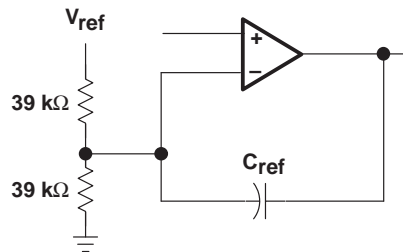
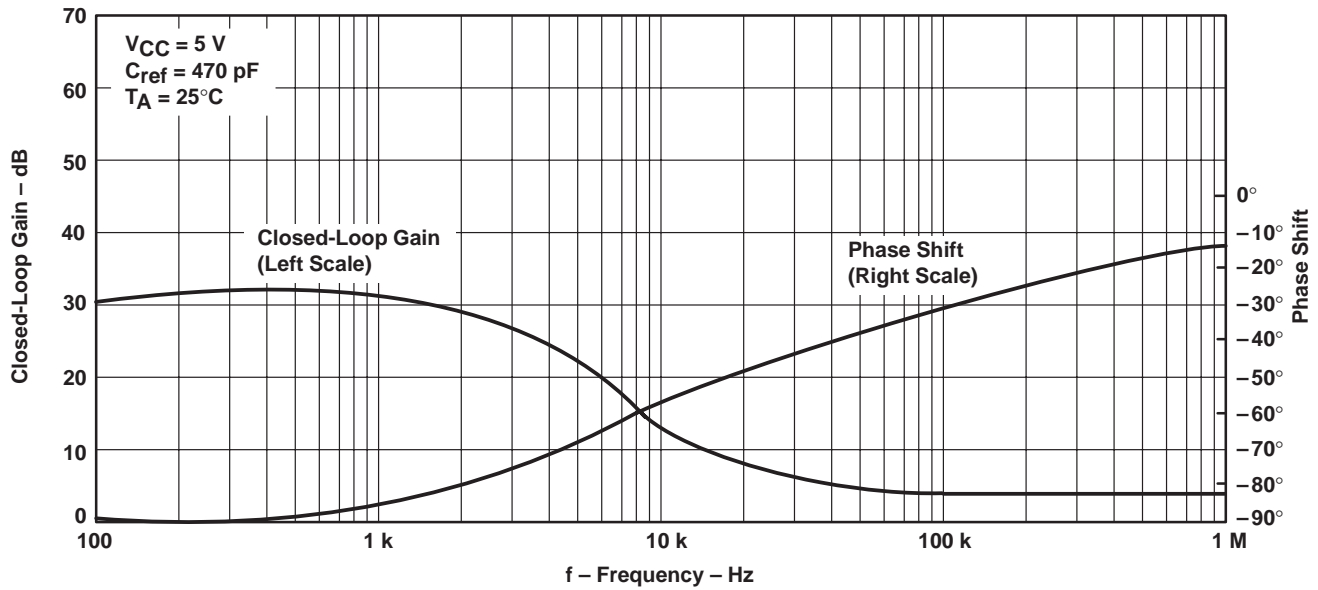

Test Circuit

Figure 21

**TYPICAL CHARACTERISTICS**

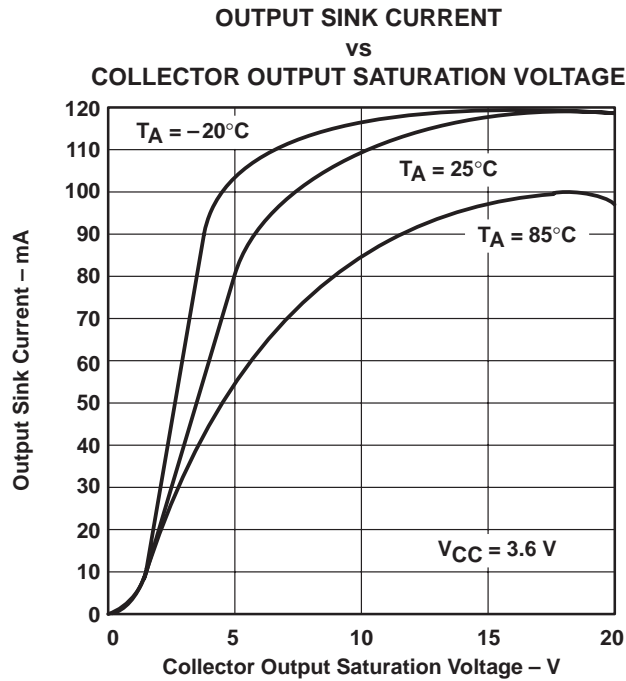

Figure 22

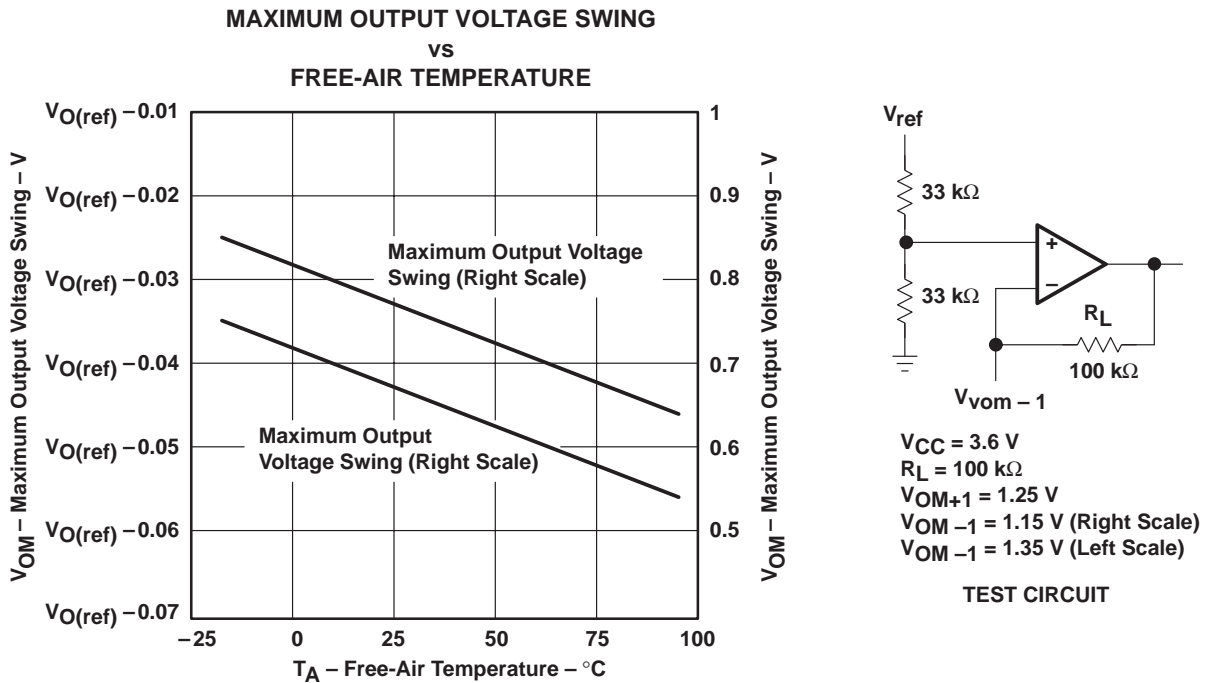
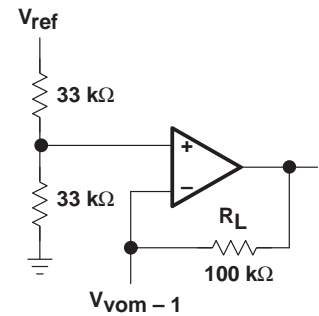

Figure 23



$V_{CC} = 3.6\text{ V}$   
 $R_L = 100\text{ k}\Omega$   
 $V_{\text{OM}+1} = 1.25\text{ V}$   
 $V_{\text{OM}-1} = 1.15\text{ V}$  (Right Scale)  
 $V_{\text{OM}-1} = 1.35\text{ V}$  (Left Scale)

TEST CIRCUIT

# TL1451A DUAL PULSE-WIDTH-MODULATION CONTROL CIRCUITS

SLVS024E – FEBRUARY 1983 – REVISED NOVEMBER 1999

## TYPICAL CHARACTERISTICS

OUTPUT TRANSISTOR ON DUTY CYCLE  
vs  
DEAD-TIME INPUT VOLTAGE

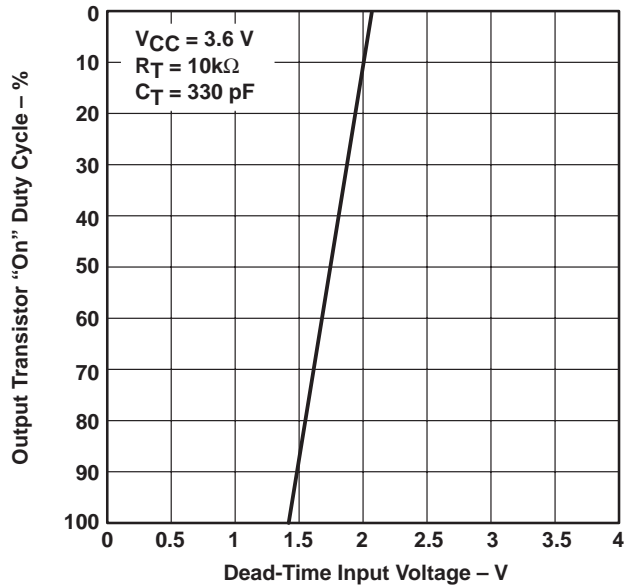

Figure 24

STANDBY CURRENT  
vs  
SUPPLY VOLTAGE

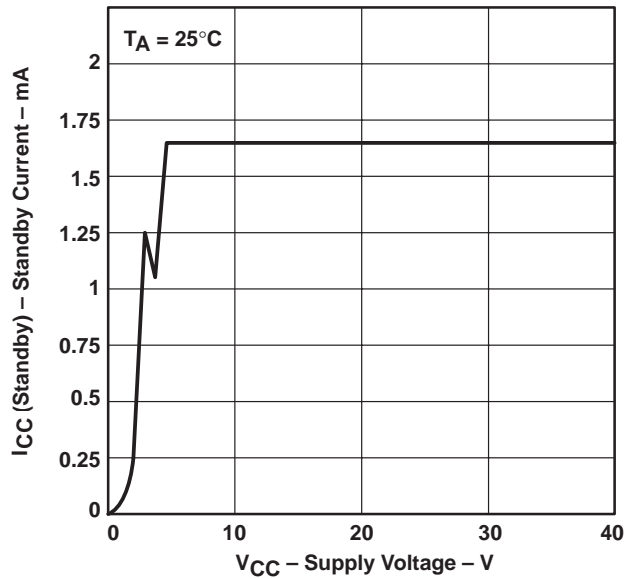

Figure 25

STANDBY CURRENT  
vs  
FREE-AIR TEMPERATURE

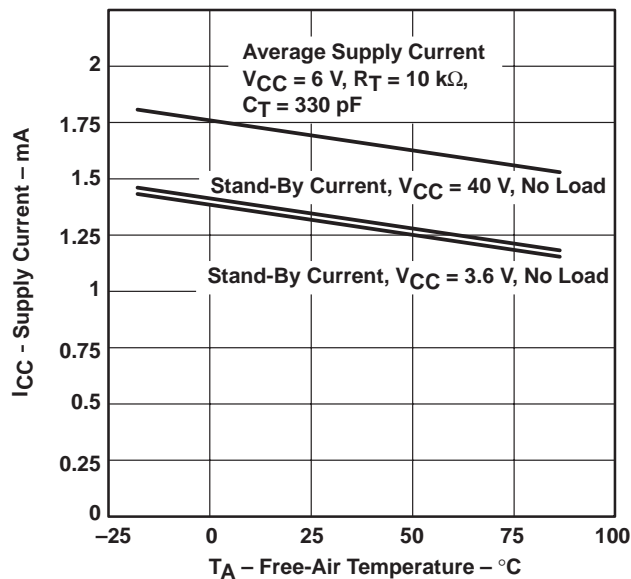

Figure 26

MAXIMUM CONTINUOUS POWER DISSIPATION  
vs  
FREE-AIR TEMPERATURE

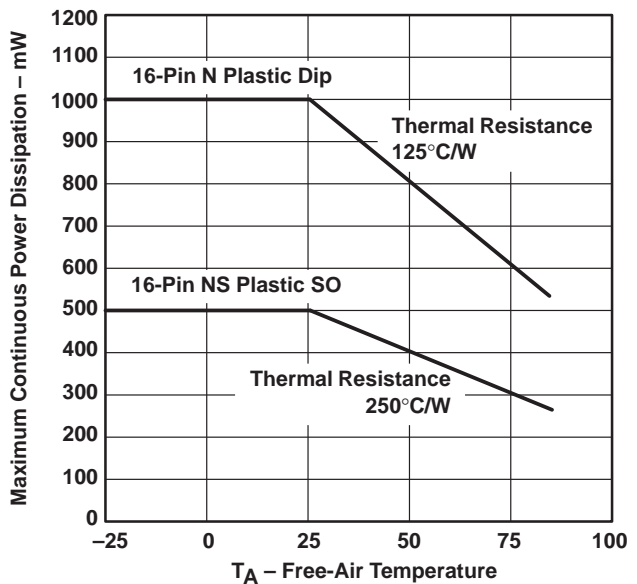
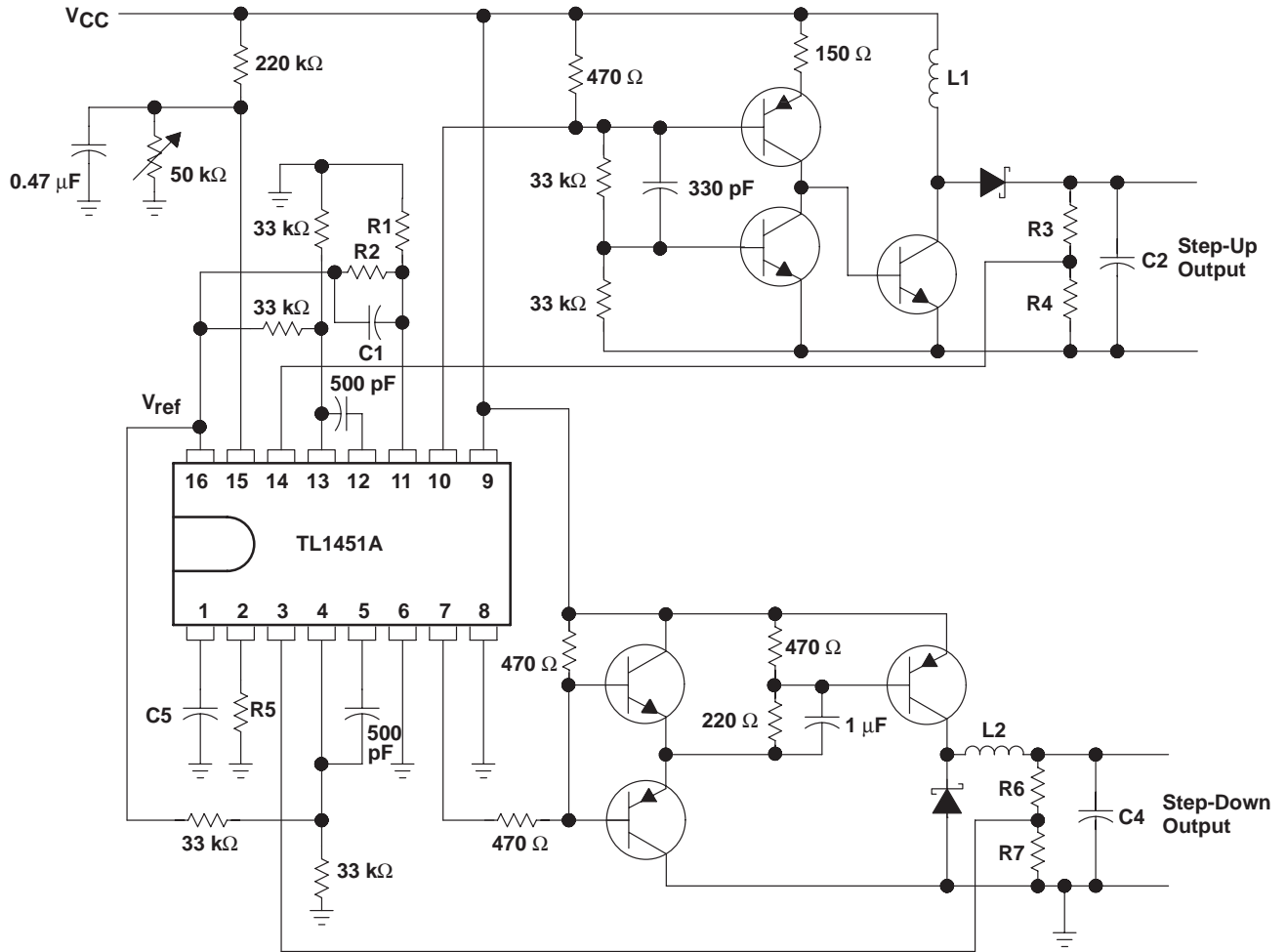

Figure 27

## APPLICATION INFORMATION



NOTE A: Values for R1 through R7, C1 through C4, and L1 and L2 depend upon individual application.

**Figure 28. High-Speed Dual Switching Regulator**

# TL1451A DUAL PULSE-WIDTH-MODULATION CONTROL CIRCUITS

SLVS024E – FEBRUARY 1983 – REVISED NOVEMBER 1999

## MECHANICAL DATA

D (R-PDSO-G\*\*)

PLASTIC SMALL-OUTLINE PACKAGE

14 PINS SHOWN

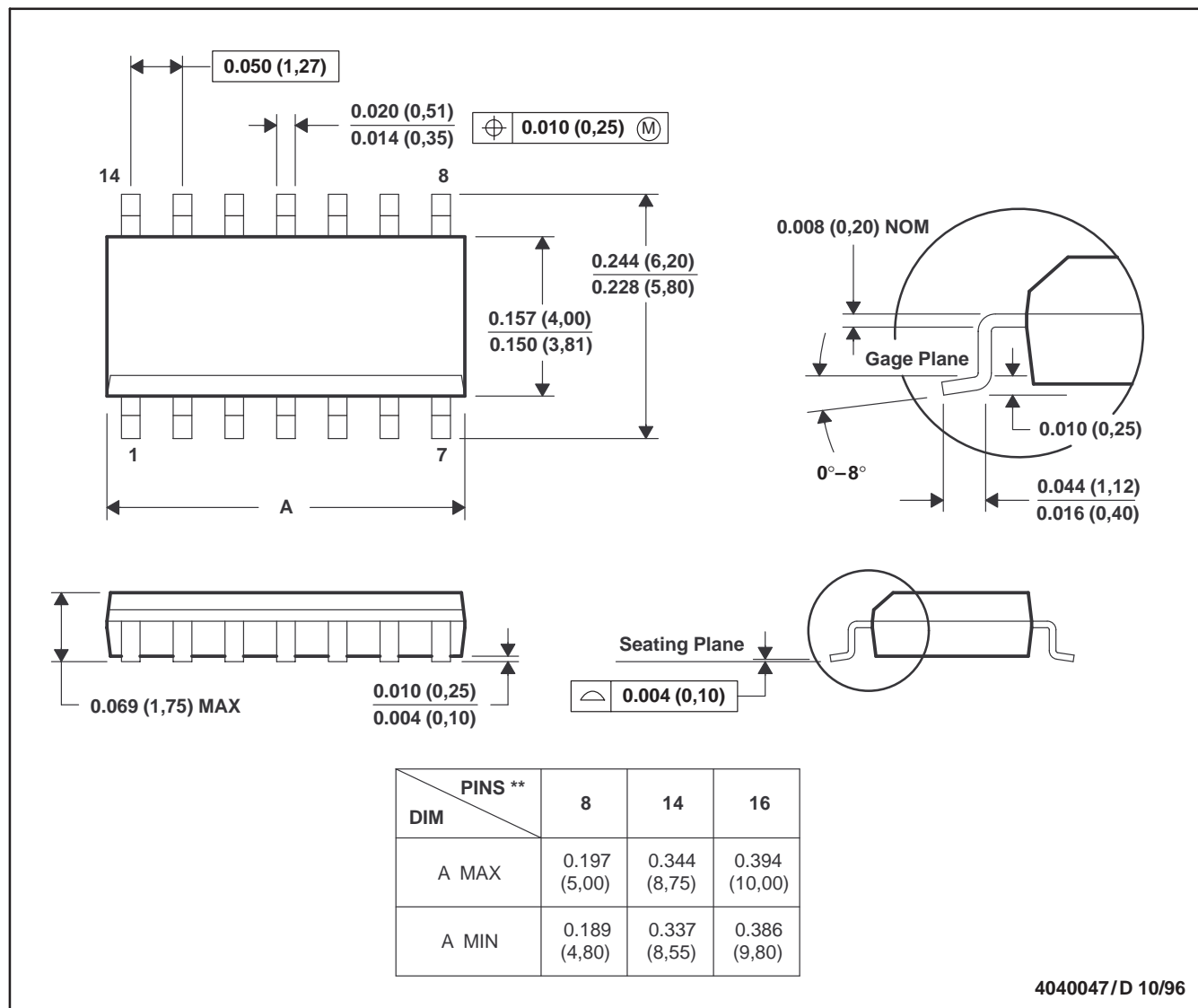

- NOTES: A. All linear dimensions are in inches (millimeters).  
 B. This drawing is subject to change without notice.  
 C. Body dimensions do not include mold flash or protrusion, not to exceed 0.006 (0,15).  
 D. Falls within JEDEC MS-012

# TL1451A DUAL PULSE-WIDTH-MODULATION CONTROL CIRCUITS

SLVS024E – FEBRUARY 1983 – REVISED NOVEMBER 1999

## MECHANICAL DATA

**DB (R-PDSO-G\*\*)**

**PLASTIC SMALL-OUTLINE PACKAGE**

28 PINS SHOWN

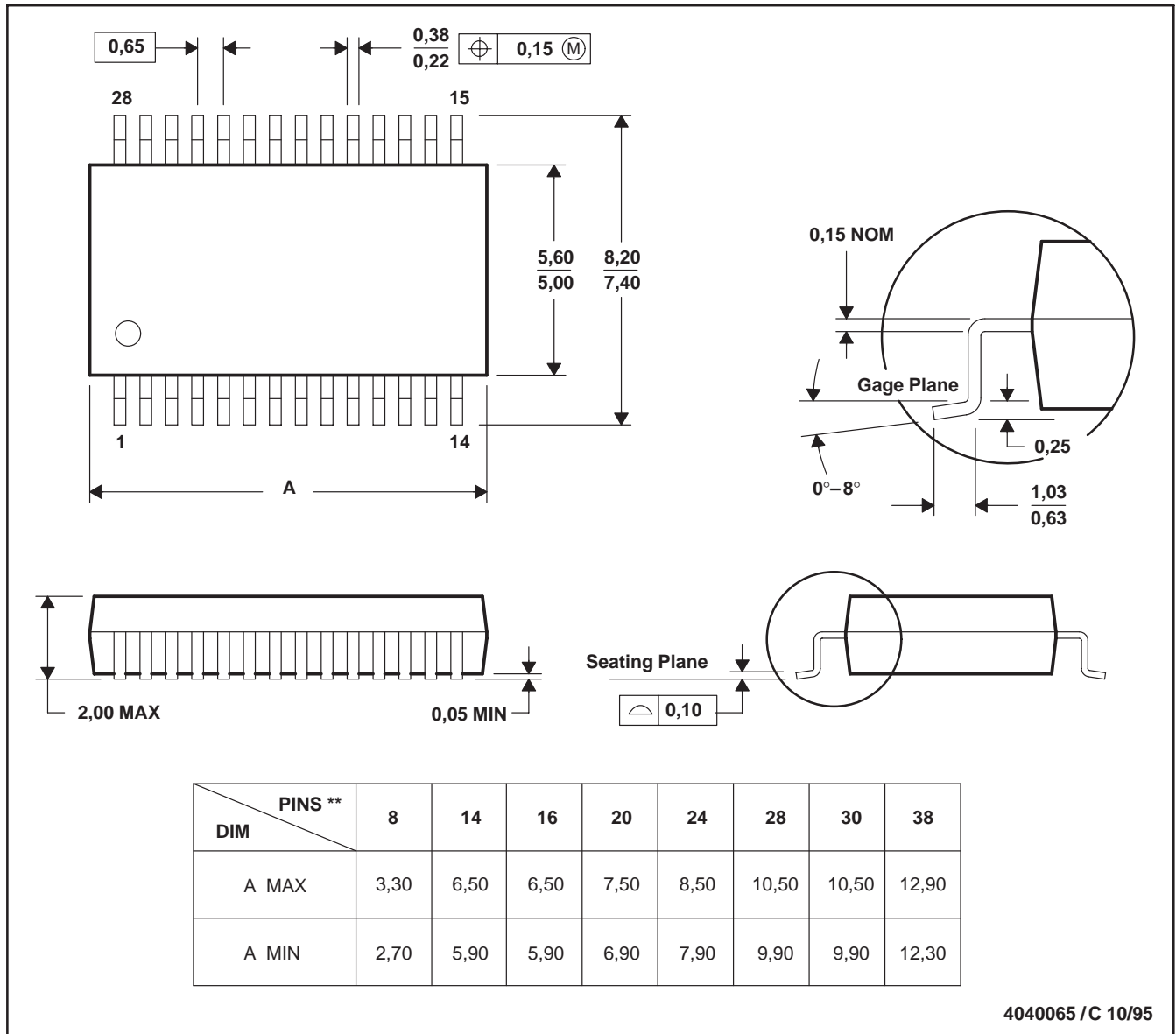

- NOTES: A. All linear dimensions are in millimeters.  
 B. This drawing is subject to change without notice.  
 C. Body dimensions do not include mold flash or protrusion not to exceed 0,15.  
 D. Falls within JEDEC MO-150

# TL1451A DUAL PULSE-WIDTH-MODULATION CONTROL CIRCUITS

SLVS024E – FEBRUARY 1983 – REVISED NOVEMBER 1999

## MECHANICAL DATA

FK (S-CQCC-N\*\*)

LEADLESS CERAMIC CHIP CARRIER

28 TERMINALS SHOWN

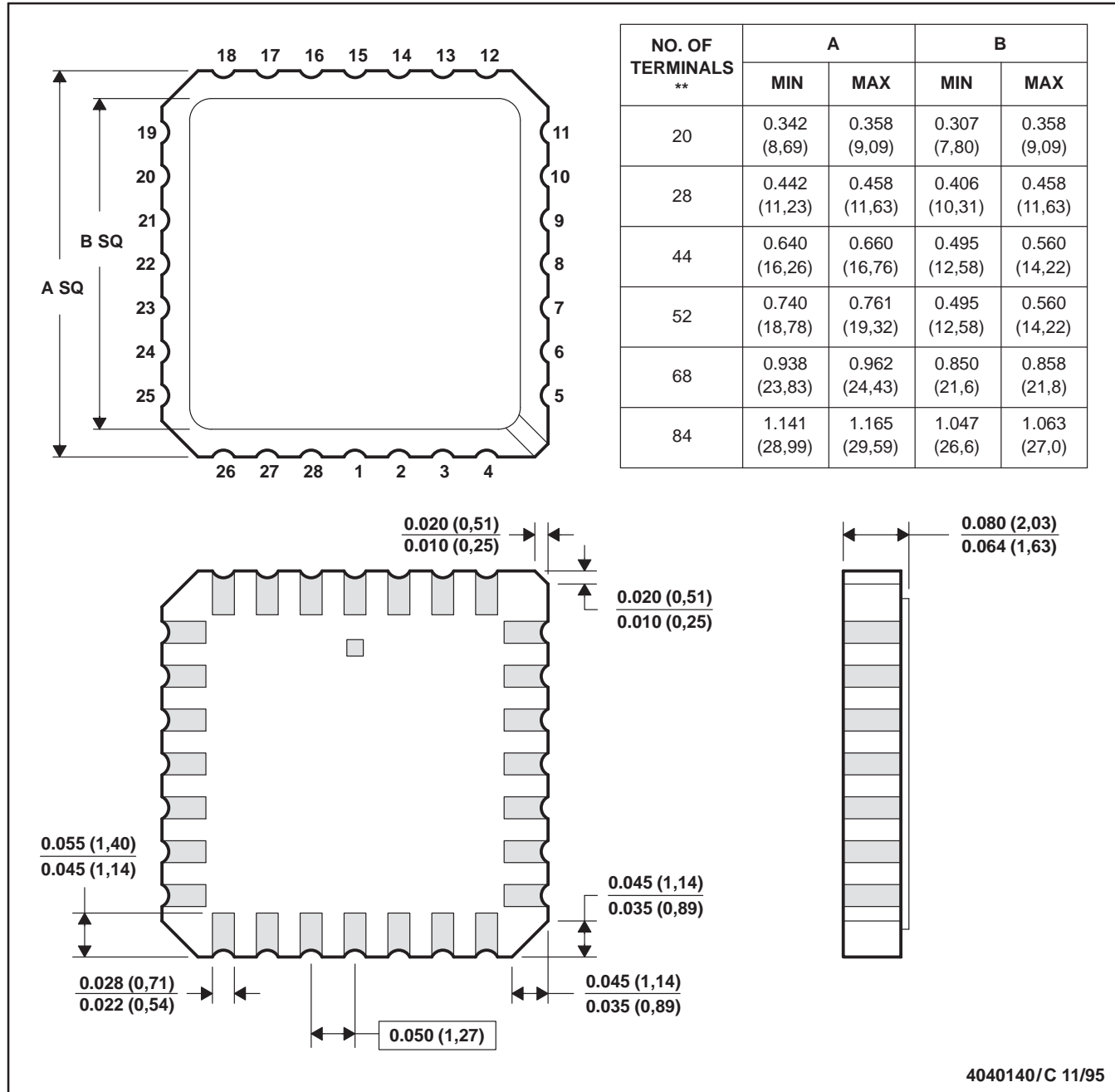

- NOTES: A. All linear dimensions are in inches (millimeters).  
 B. This drawing is subject to change without notice.  
 C. This package can be hermetically sealed with a metal lid.  
 D. The terminals are gold-plated.  
 E. Falls within JEDEC MS-004



# TL1451A DUAL PULSE-WIDTH-MODULATION CONTROL CIRCUITS

SLVS024E – FEBRUARY 1983 – REVISED NOVEMBER 1999

## MECHANICAL DATA

**J (R-GDIP-T\*\*)**

**CERAMIC DUAL-IN-LINE**

14 LEADS SHOWN

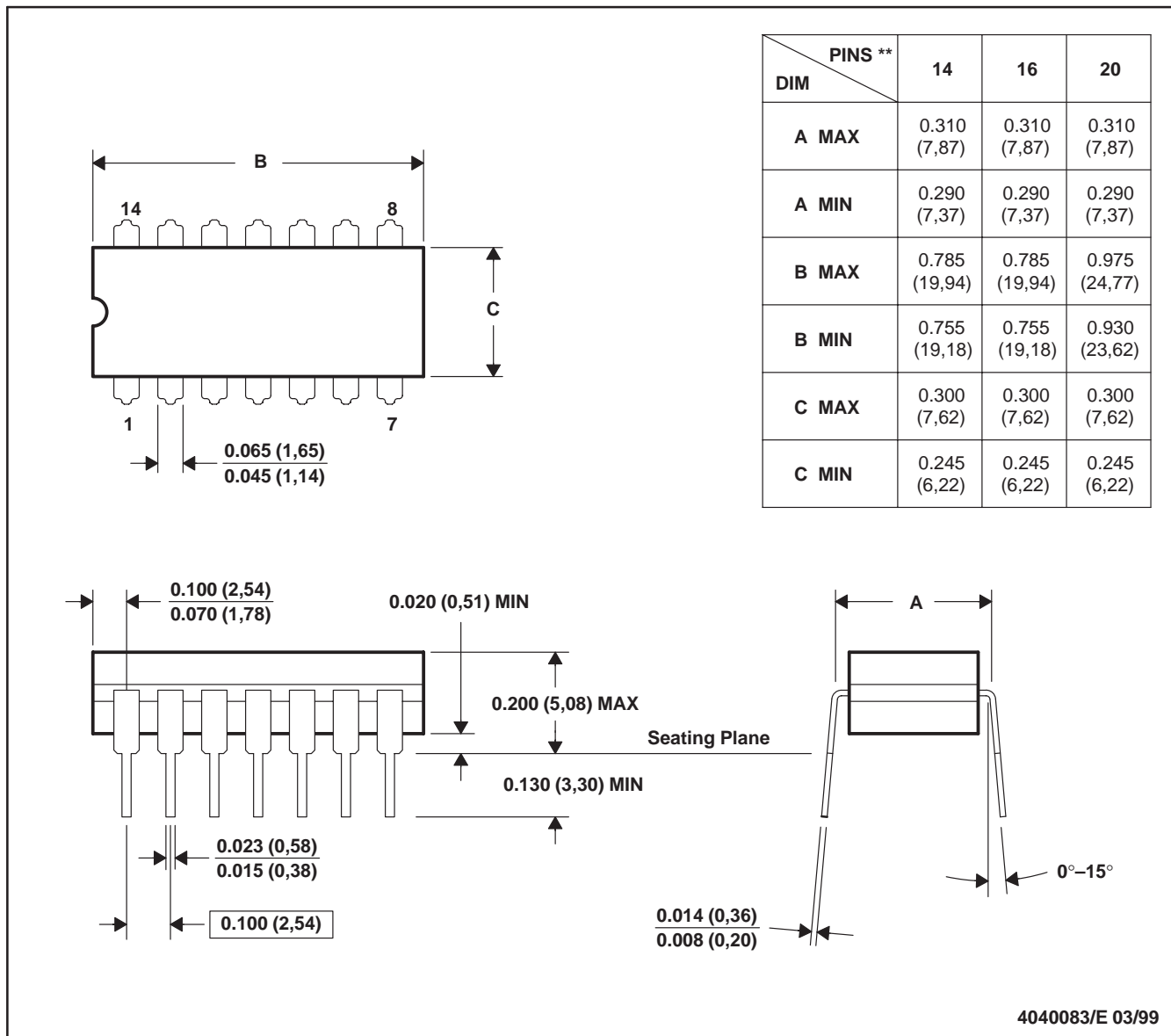

- NOTES:
- A. All linear dimensions are in inches (millimeters).
  - B. This drawing is subject to change without notice.
  - C. This package is hermetically sealed with a ceramic lid using glass frit.
  - D. Index point is provided on cap for terminal identification.
  - E. Falls within MIL STD 1835 GDIP1-T14, GDIP1-T16, and GDIP1-T20

# TL1451A DUAL PULSE-WIDTH-MODULATION CONTROL CIRCUITS

SLVS024E – FEBRUARY 1983 – REVISED NOVEMBER 1999

## MECHANICAL DATA

**N (R-PDIP-T\*\*)**  
16 PINS SHOWN

**PLASTIC DUAL-IN-LINE PACKAGE**

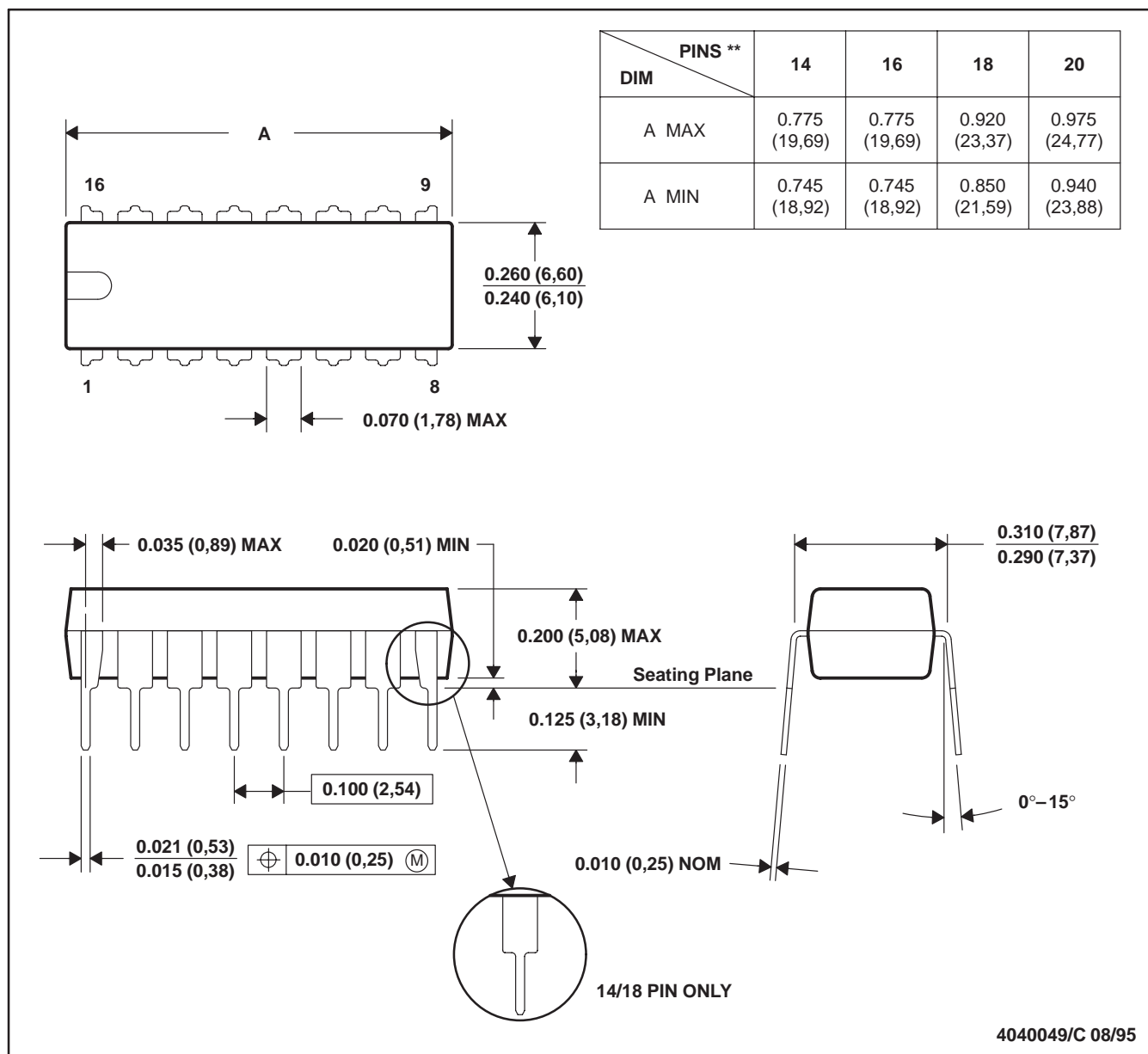

- NOTES: A. All linear dimensions are in inches (millimeters).  
 B. This drawing is subject to change without notice.  
 C. Falls within JEDEC MS-001 (20-pin package is shorter than MS-001).

# TL1451A DUAL PULSE-WIDTH-MODULATION CONTROL CIRCUITS

SLVS024E – FEBRUARY 1983 – REVISED NOVEMBER 1999

## MECHANICAL DATA

**NS (R-PDSO-G\*\*)**

**PLASTIC SMALL-OUTLINE PACKAGE**

14 PINS SHOWN

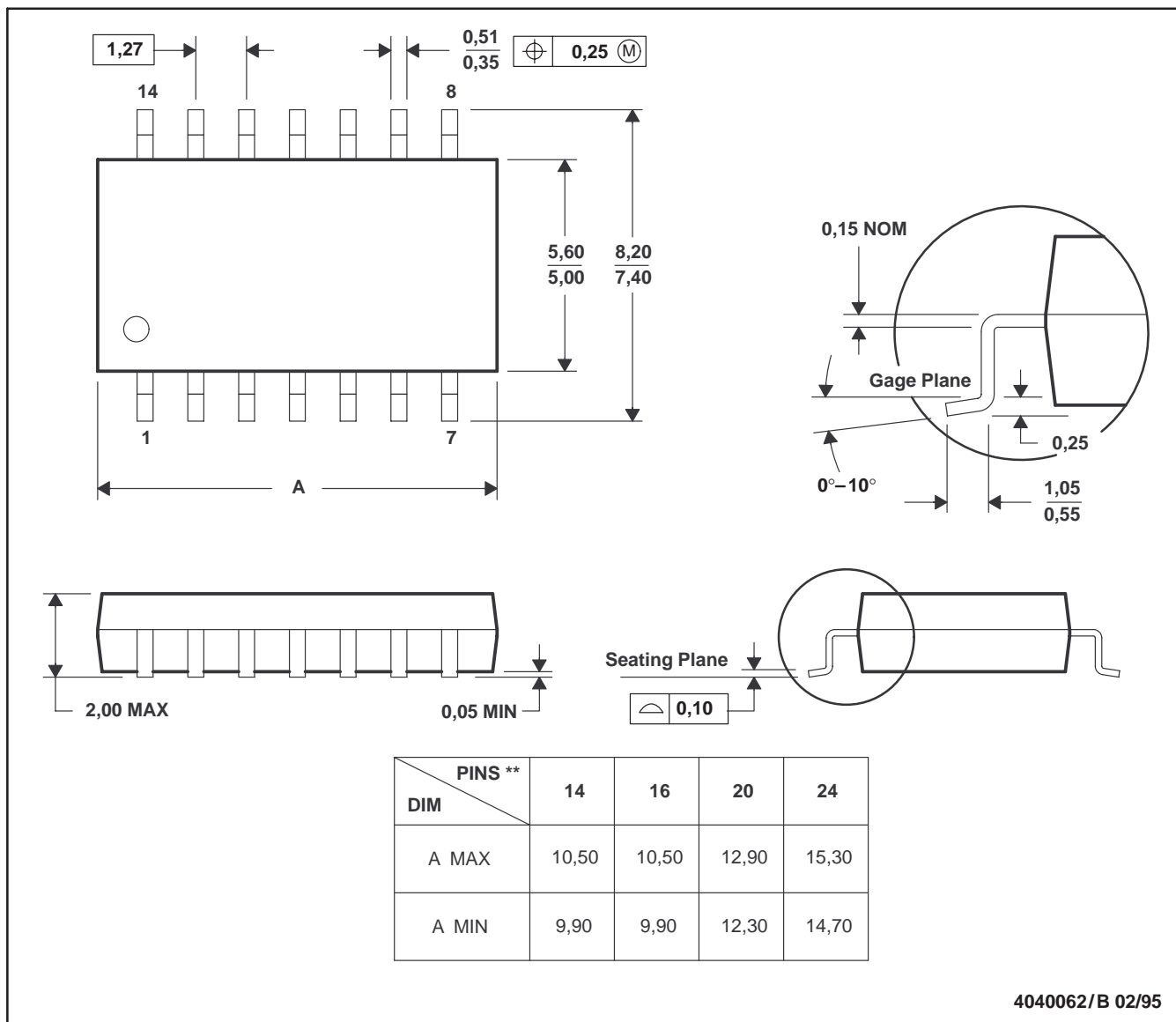

- NOTES: A. All linear dimensions are in millimeters.  
 B. This drawing is subject to change without notice.  
 C. Body dimensions do not include mold flash or protrusion, not to exceed 0,15.

# TL1451A DUAL PULSE-WIDTH-MODULATION CONTROL CIRCUITS

SLVS024E – FEBRUARY 1983 – REVISED NOVEMBER 1999

## MECHANICAL DATA

PW (R-PDSO-G\*\*)

PLASTIC SMALL-OUTLINE PACKAGE

14 PINS SHOWN

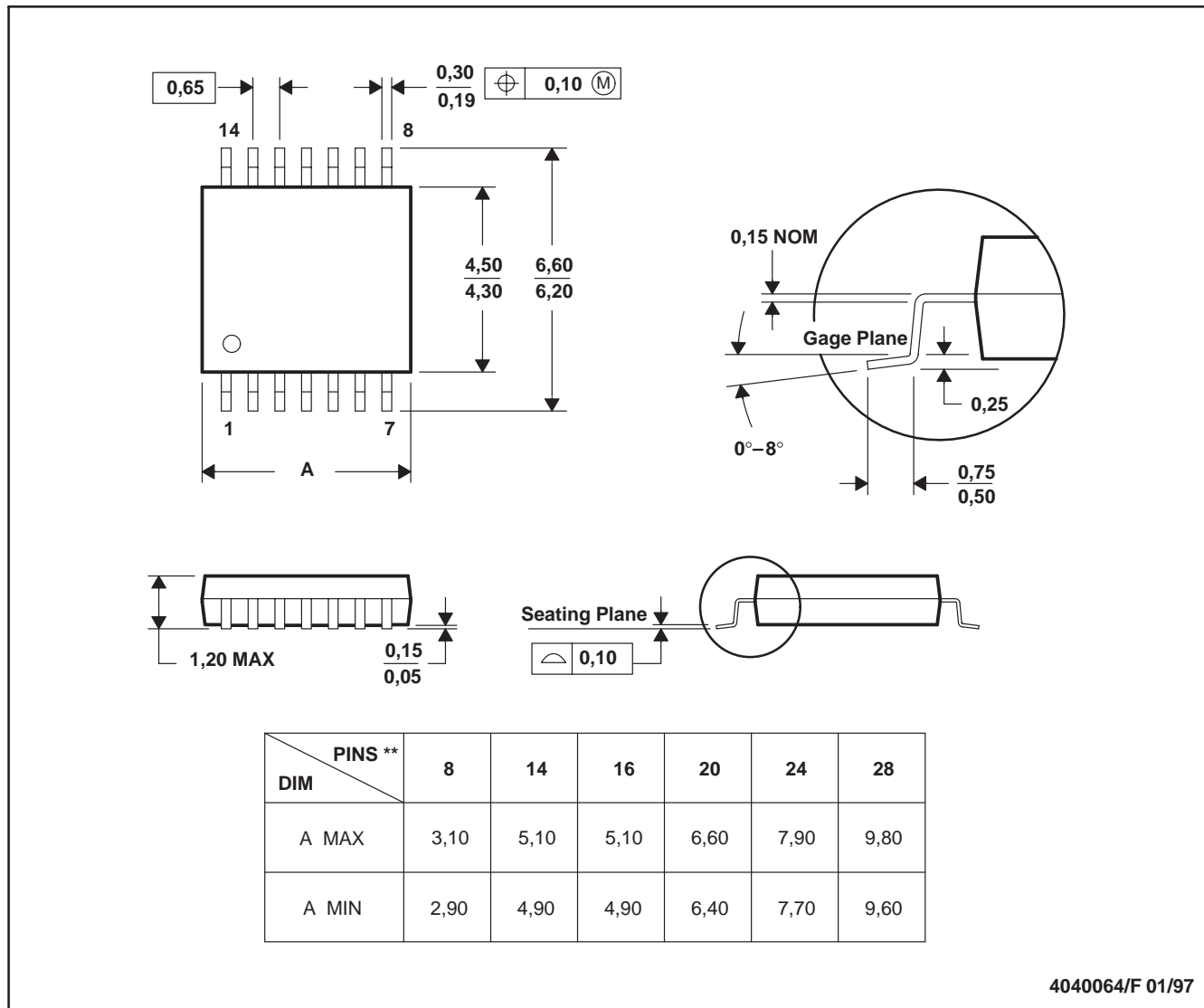

- NOTES: A. All linear dimensions are in millimeters.  
 B. This drawing is subject to change without notice.  
 C. Body dimensions do not include mold flash or protrusion not to exceed 0,15.  
 D. Falls within JEDEC MO-153

## IMPORTANT NOTICE

Texas Instruments and its subsidiaries (TI) reserve the right to make changes to their products or to discontinue any product or service without notice, and advise customers to obtain the latest version of relevant information to verify, before placing orders, that information being relied on is current and complete. All products are sold subject to the terms and conditions of sale supplied at the time of order acknowledgement, including those pertaining to warranty, patent infringement, and limitation of liability.

TI warrants performance of its semiconductor products to the specifications applicable at the time of sale in accordance with TI's standard warranty. Testing and other quality control techniques are utilized to the extent TI deems necessary to support this warranty. Specific testing of all parameters of each device is not necessarily performed, except those mandated by government requirements.

CERTAIN APPLICATIONS USING SEMICONDUCTOR PRODUCTS MAY INVOLVE POTENTIAL RISKS OF DEATH, PERSONAL INJURY, OR SEVERE PROPERTY OR ENVIRONMENTAL DAMAGE ("CRITICAL APPLICATIONS"). TI SEMICONDUCTOR PRODUCTS ARE NOT DESIGNED, AUTHORIZED, OR WARRANTED TO BE SUITABLE FOR USE IN LIFE-SUPPORT DEVICES OR SYSTEMS OR OTHER CRITICAL APPLICATIONS. INCLUSION OF TI PRODUCTS IN SUCH APPLICATIONS IS UNDERSTOOD TO BE FULLY AT THE CUSTOMER'S RISK.

In order to minimize risks associated with the customer's applications, adequate design and operating safeguards must be provided by the customer to minimize inherent or procedural hazards.

TI assumes no liability for applications assistance or customer product design. TI does not warrant or represent that any license, either express or implied, is granted under any patent right, copyright, mask work right, or other intellectual property right of TI covering or relating to any combination, machine, or process in which such semiconductor products or services might be or are used. TI's publication of information regarding any third party's products or services does not constitute TI's approval, warranty or endorsement thereof.

This datasheet has been downloaded from:

[www.DatasheetCatalog.com](http://www.DatasheetCatalog.com)

Datasheets for electronic components.

# Texas Instruments

<http://www.ti.com>

This file is the datasheet for the following electronic components:

TL1451ACDB - <http://www.ti.com/product/tl1451acdb?HQS=TI-null-null-dscatalog-df-pf-null-wwe>

TL1451AD - <http://www.ti.com/product/tl1451ad?HQS=TI-null-null-dscatalog-df-pf-null-wwe>

TL1451ACNS - <http://www.ti.com/product/tl1451acns?HQS=TI-null-null-dscatalog-df-pf-null-wwe>

TL1451AMFK - <http://www.ti.com/product/tl1451amfk?HQS=TI-null-null-dscatalog-df-pf-null-wwe>

TL1451ADB - <http://www.ti.com/product/tl1451adb?HQS=TI-null-null-dscatalog-df-pf-null-wwe>

TL1451AJ - <http://www.ti.com/product/tl1451aj?HQS=TI-null-null-dscatalog-df-pf-null-wwe>

TL1451 - <http://www.ti.com/product/tl1451?HQS=TI-null-null-dscatalog-df-pf-null-wwe>

TL1451APW - <http://www.ti.com/product/tl1451apw?HQS=TI-null-null-dscatalog-df-pf-null-wwe>

TL1451ANS - <http://www.ti.com/product/tl1451ans?HQS=TI-null-null-dscatalog-df-pf-null-wwe>

TL1451AN - <http://www.ti.com/product/tl1451an?HQS=TI-null-null-dscatalog-df-pf-null-wwe>

TL1451AFK - <http://www.ti.com/product/tl1451afk?HQS=TI-null-null-dscatalog-df-pf-null-wwe>