

LM19264KCC

LCD Module User Manual

Shenzhen TOPWAY Technology Co., Ltd.

| Rev. | Descriptions | Release Date |
|------|-------------------------|--------------|
| 0.1 | Preliminary new release | 2006-07-10 |
| | | |
| | | |
| | | |

Table of Content

| | |
|---|-----------|
| 1. Basic Specifications | 3 |
| 1.1 Display Specifications | 3 |
| 1.2 Mechanical Specifications | 3 |
| 1.3 Environmental Safe Specifications | 3 |
| 1.4 Block Diagram | 3 |
| 1.5 Terminal Functions | 4 |
| 2. Absolute Maximum Ratings | 5 |
| 3. Electrical Characteristics | 5 |
| 3.1 DC Characteristics | 5 |
| 3.2 LED Backlight Circuit Characteristics | 5 |
| 3.3 AC Characteristics | 6 |
| 4. Function Specifications | 7 |
| 4.1 Basic Setting | 7 |
| 4.2 Adjusting the LCD display contrast | 7 |
| 4.3 Resetting the LCD module | 7 |
| 4.4 Display Memory Map | 8 |
| 4.5 Internal Registers | 8 |
| 4.6 Display Control Instructions | 9 |
| 5. Design and Handling Precaution | 10 |

1. Basic Specifications

1.1 Display Specifications

- 1) LCD Display Mode : FSTN, Positive, Transflective
- 2) Display Color : Display Data = "1" : Dark Gray (*1)
: Display Data = "0" : Light Gray (*2)
- 3) Viewing Angle : 6 H
- 4) Driving Method : 1/64 duty, 1/9 bias
- 5) Back Light : White LED backlight

Note:

*1. Color tone may slightly change by Temperature and Driving Condition.

*2. The Color is defined as the inactive / background color

1.2 Mechanical Specifications

- 1) Outline Dimension : 130.0 x 65.0 x 12.6MAX (exclude FFC)
(see attached Outline Drawing for details)

1.3 Environmental Safe Specifications

This product, LM19264D-6b, conforms ROHS regulation.

1.4 Block Diagram

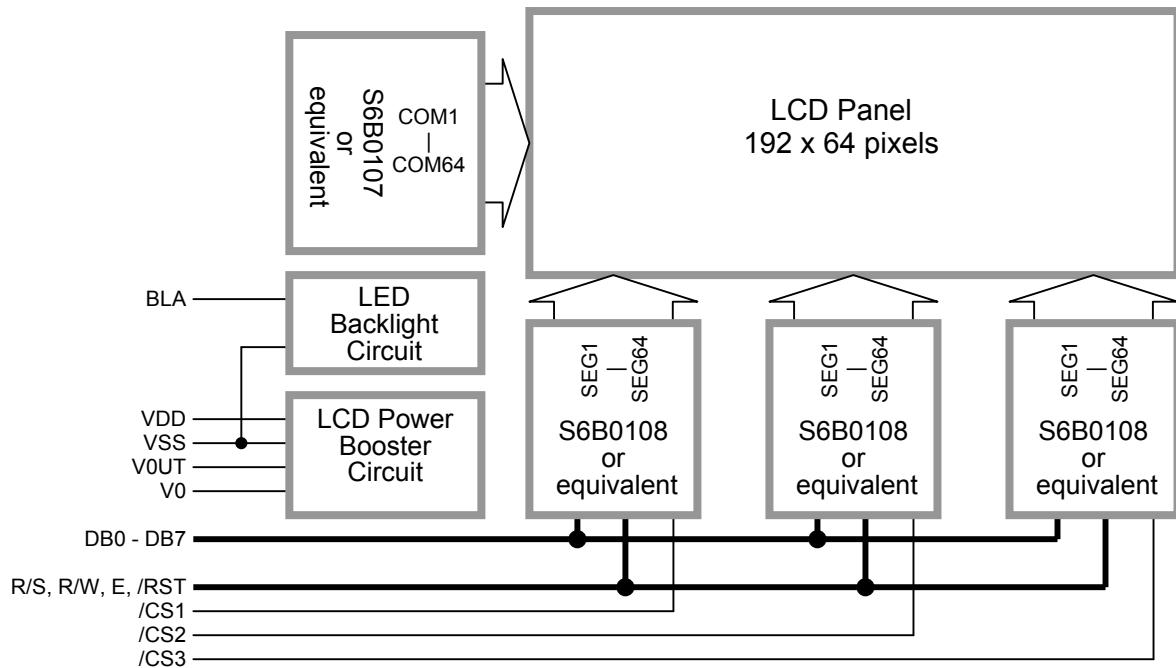

1.5 Terminal Functions

| Pin No. | Pin Name | I/O | Descriptions |
|---------|----------|--------|--|
| 1 | VSS | Power | Negative Power Supply, Ground (0V) |
| 2 | VDD | Power | Positive Power Supply |
| 3 | V0 | Power | LCD Contrast reference |
| 4 | R/S | Input | R/S = H; DB0 – DB7 = Display RAM data R/S = L; DB0 – DB7 = Instruction data |
| 5 | R/W | Input | In read mode |
| 6 | E | Input | R/W = H; Data read from the LCD module, data appears at DB0 – DB7 and can be read by the host while, E = H and the device is being selected In write mode R/W = L; Data write to the LCD module, data appears at DB0 – DB7 will be written into the LCD module at E = H→L and device is being selected |
| 7 | DB0 | I/O | Data bus; Three state I/O terminal for display data or instruction data |
| : | : | | |
| 14 | DB7 | | |
| 15 | /CS1 | Input | Chip selection, enable access to left section of the LCD module (*1) |
| 16 | /RST | Input | Reset signal /RST = L, Display off display start line register becomes 0 no command or instruction data could be accepted /RST = H, Normal running |
| 17 | /CS2 | Input | Chip selection, enable access to middle section of the LCD module (*1) |
| 18 | /CS3 | Input | Chip selection, enable access to right section of the LCD module (*1) |
| 19 | VOOUT | Output | Power Booster output for V0 |
| 20 | BLA | Power | Positive Power for LED backlight |

Note:

- *1. Display or instruction data could write into the LCD module's driver/controllers individually or at the same time.
Only read display or instruction data from one of the driver/controller in the LCD module at a time, otherwise unexpected data collision may occur.

2. Absolute Maximum Ratings

| Items | Symbol | Min. | Max. | Unit | Condition |
|-----------------------|----------|------|------|------|-----------------|
| Supply Voltage | V_{DD} | 0 | 7.0 | V | $V_{SS} = 0V$ |
| Operating Temperature | T_{OP} | -20 | 70 | °C | No Condensation |
| Storage Temperature | T_{ST} | -30 | 80 | °C | No Condensation |

Cautions:

Any Stresses exceeding the Absolute Maximum Ratings may cause substantial damage to the device. Functional operation of this device at other conditions beyond those listed in the specification is not implied and prolonged exposure to extreme conditions may affect device reliability.

3. Electrical Characteristics

3.1 DC Characteristics

$V_{SS}=0V, V_{DD} =5V, T_{OP} =25^{\circ}C$

| Items | Symbol | MIN. | TYP. | MAX. | Unit | Applicable Pin |
|--------------------|----------|------|------|----------|------|--------------------------|
| Operating Voltage | V_{DD} | 4.8 | 5.0 | 5.2 | V | VDD |
| Input High Voltage | V_{IH} | 3.5 | - | V_{DD} | V | R/S, R/W, E, /CS1, /CS2, |
| Input Low Voltage | V_{IL} | 0 | - | 0.4 | V | /CS3, DB0-DB7 |
| Operating Current | I_{DD} | - | 7.5 | 15 | mA | VDD, VSS |

3.2 LED Backlight Circuit Characteristics

$V_{SS}=0V, I_{f_{BLA}}=160mA, T_{OP} =25^{\circ}C$

| Items | Symbol | MIN. | TYP. | MAX. | Unit | Applicable Pin |
|-----------------|---------------|------|------|------|------|----------------|
| Forward Voltage | $V_{f_{BLA}}$ | - | 5.0 | - | V | BLA |
| Forward Current | $I_{f_{BLA}}$ | - | - | 200 | mA | BLA |

Cautions:

Exceeding the recommended driving current could cause substantial damage to the backlight and shorten its lifetime.

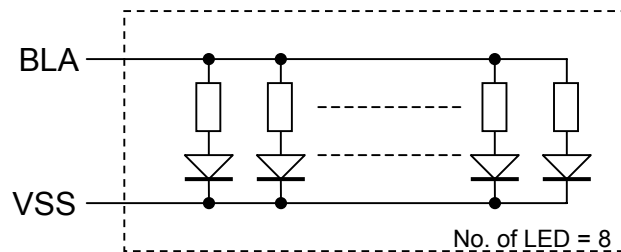

3.3 AC Characteristics

$V_{SS}=0V, V_{DD}=5V, T_{OP}=25^{\circ}C$

| Item | Symbol | MIN. | TYP. | MAX. | Unit |
|------------------------|--------|------|------|------|------|
| E cycle time | tc | 1500 | - | - | ns |
| E high level width | twh | 700 | - | - | ns |
| E low level width | twl | 700 | - | - | ns |
| E rise time | tr | - | - | 18 | ns |
| E fall time | tf | - | - | 18 | ns |
| Address set-up time | tasu | 210 | - | - | ns |
| Address hold time | tah | 15 | - | - | ns |
| Data set-up time | tdsu | 300 | - | - | ns |
| Data delay time | td | - | - | 480 | ns |
| Data hold time (write) | tdhw | 15 | - | - | ns |
| Data hold time (read) | tdhr | 30 | - | - | ns |

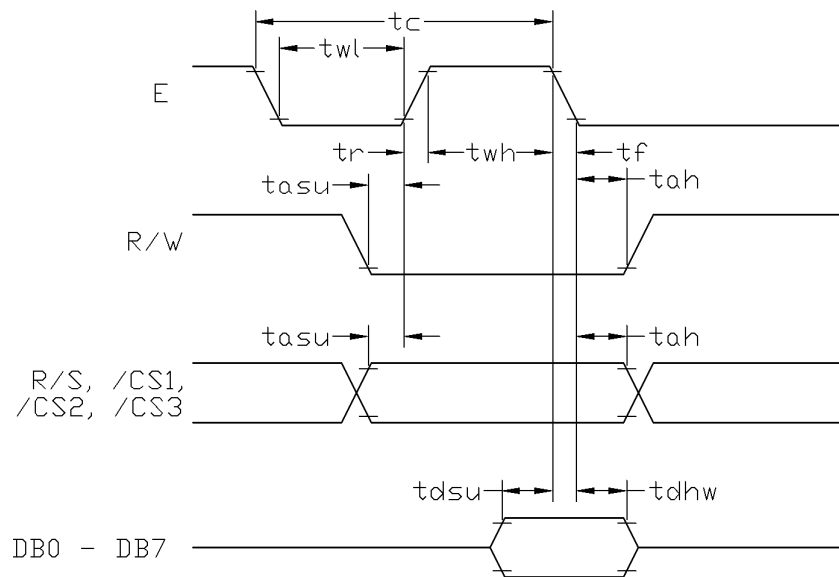

Host Write Timing Diagram

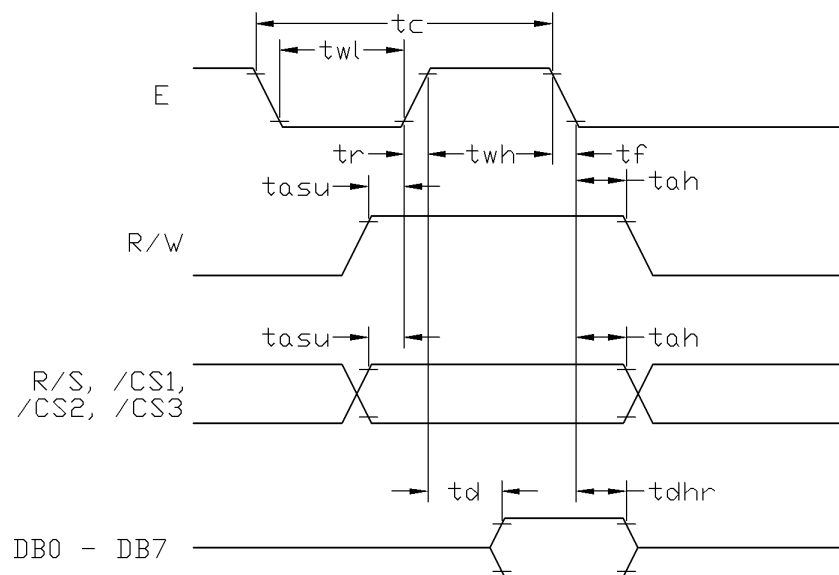

Host Read Timing Diagram

4. Function Specifications

4.1 Basic Setting

To drive the LCD module correctly and provide normally display, please use the following setting

Display start line (Z address)= 0
 LCD Display = on

Note:

These setting/commands should issue to both controllers while start up.
 See the Display Control Instructions section for details.

4.2 Adjusting the LCD display contrast

A Variable-Resistor must be connected to the LCD module for providing a reference to V0. Adjusting the VR will result the change of LCD display contrast. The recommended value of VR is 25k to 50k

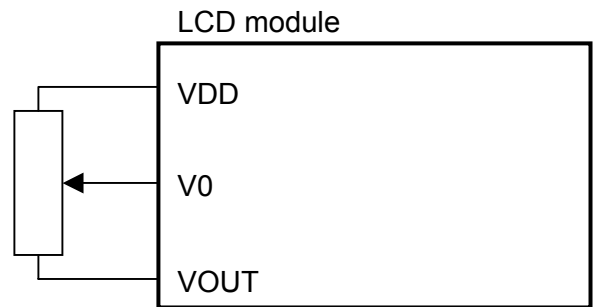

4.3 Resetting the LCD module

The LCD module should be initialized by setting /RST terminal at low level when turning the power on.

When /RST pull low, the LCD module will:

- Display off
- Display start line register becomes 0. (Z-address=0)

While /RST is low, no instruction can be accepted except status read. Therefore, execute other instructions after making sure that DB4=0 (clear /RST) and DB7=0 (ready) by status read instruction. The conditions of power supply at initial power up are as follow:

| Item | Symbol | MIN. | TYP. | MAX. | Unit |
|------------|--------|------|------|------|------|
| Reset time | trs | 2.0 | - | - | us |
| Rise time | tr | - | - | 150 | ns |

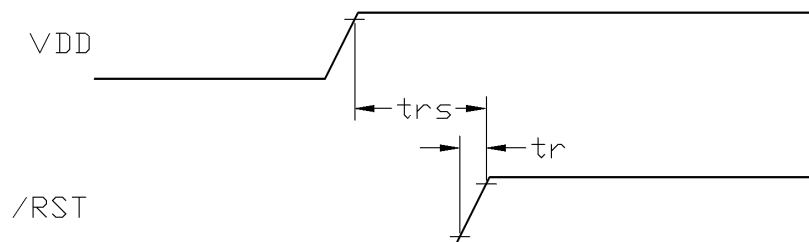

4.4 Display Memory Map

| Page (X) address | data | LCD Display (front view) | | |
|----------------------|---------------|--------------------------|-----------|-----------|
| 0 | D0 : D7 | | | |
| 1 | D0 : D7 | | | |
| 2 | D0 : D7 | | | |
| 3 | D0 : D7 | | | |
| 4 | D0 : D7 | | | |
| 5 | D0 : D7 | | | |
| 6 | D0 : D7 | | | |
| 7 | D0 : D7 | | | |
| Column(Y) Address | | 00h → 3Fh | 00h → 3Fh | 00h → 3Fh |
| Driver (accessed by) | | /CS1 | /CS2 | /CS3 |

Note:

- 1) Display start line (Z address) = 0
- 2) The Display Data store separately in three drivers.
- 3) The Display Data for the left section could be accessed by /CS1.
The Display Data for the middle section could be accessed by /CS2.
The Display Data for the right section could be accessed by /CS3.

4.5 Internal Registers

There are three registers in each section of LCD module. Each of them could be controlled independently.

Page (X) Address Register

X address register designates pages of the internal display data RAM. Count function is not available. The address should set by instruction.

Column (Y) Address Counter

Y address counter designates address of the internal display data RAM. It could be set by instruction and is increased by 1 automatically by read or write display data operations.

Display Start Line (Z) Register

Z address register indicates of display data RAM to LCD top line. It may be used for scrolling the display pattern on the LCD.

4.6 Display Control Instructions

| Instructions | Code | | | | | | | | | | | Function | Note |
|------------------------------------|------|-----|------------|-----|------------------|-------|-----|-----------------|-----|-----|-----|--|------|
| | R/S | R/W | DB7 | DB6 | DB5 | DB4 | DB3 | DB2 | DB1 | DB0 | | | |
| Display on/off | 0 | 0 | 0 | 0 | 1 | 1 | 1 | 1 | 1 | 1 | 1/0 | Controls the display on or off. Internal status and display data in RAM is not affected 0=off, 1=on | *2 |
| Set Column (Y) Address | 0 | 0 | 0 | 1 | Y address (0-63) | | | | | | | Set the Column address into the Y address counter | *2 |
| Set Page (X) Address | 0 | 0 | 1 | 0 | 1 | 1 | 1 | X address (0-7) | | | | Set the Page address into the X address register | *2 |
| Set Display Start Line (Z address) | 0 | 0 | 1 | 1 | Z address (0-63) | | | | | | | Indicates the display data RAM displayed at the top of the screen | *2 |
| Status Read | 0 | 1 | Busy | 0 | on/off | Reset | 0 | 0 | 0 | 0 | 0 | Read status Busy=L, Driver ready; Busy=H, Driver busy on/off=L, Display is on; on/off=H, Display is off Reset=L, Normal Running; Reset=H, reset | *1 |
| Write Display Data | 1 | 0 | Write data | | | | | | | | | Write display data into display data RAM, After writing instruction, Y address counter increased by 1 automatically | *2 |
| Read Display Data | 1 | 1 | Read data | | | | | | | | | Read display data form the display data RAM | *1 |

Note:

- *1. Only one section (driver) could be read at the same time.
i.e. only the following setting is valid for the operation:
/CS1=0, /CS2=1, /CS3=1 is valid
/CS1=1, /CS2=0, /CS3=1 is valid
/CS1=1, /CS2=1, /CS3=0 is valid
- *2. Instruction could be write into both drivers at the same time.
- *3. For the details of the Display Control Instructions, please refer to S6B0108 handbook.

5. Design and Handling Precaution

1. The LCD panel is made by glass. Any mechanical shock (eg. dropping from high place) will damage the LCD module.
2. Do not add excessive force on the surface of the display, which may cause the Display color change abnormally.
3. The polarizer on the LCD is easily get scratched. If possible, do not remove the LCD protective film until the last step of installation.
4. Never attempt to disassemble or rework the LCD module.
5. Only Clean the LCD with Isopropyl Alcohol or Ethyl Alcohol. Other solvents (eg. water) may damage the LCD.
6. When mounting the LCD module, make sure that it is free from twisting, warping and distortion.
7. Ensure to provide enough space (with cushion) between case and LCD panel to prevent external force adding on it, or it may cause damage to the LCD or degrade the display result.
8. Only hold the LCD module by its side. Never hold LCD module by add force on the heat seal or TAB.
9. Never add force to component of the LCD module. It may cause invisible damage or degrade of the reliability.
10. LCD module could be easily damaged by static electricity. Be careful to maintain an optimum anti-static work environment to protect the LCD module.
11. When peeling off the protective film from LCD, static charge may cause abnormal display pattern. It is normal and will resume to normal in a short while.
12. Take care and prevent get hurt by the LCD panel sharp edge.
13. Never operate the LCD module exceed the absolute maximum ratings.
14. Keep the signal line as short as possible to prevent noisy signal applying to LCD module.
15. Never apply signal to the LCD module without power supply.
16. IC chip (eg. TAB or COG) is sensitive to the light. Strong lighting environment could possibly cause malfunction. Light sealing structure casing is recommend.
17. LCD module reliability may be reduced by temperature shock.
18. When storing the LCD module, avoid exposure to the direct sunlight, high humidity, high temperature or low temperature. They may damage or degrade the LCD module